

RADIO

ESTABLISHED 1917

THE TECHNICAL AUTHORITY OF AMATEUR RADIO

OHM'S LAW

$$E = I \times R$$

$$R = \frac{E}{I}$$

$$I = \frac{E}{R}$$

CONDENSERS IN SERIES

$$C_{TOTAL} = \frac{C_1 \times C_2}{C_1 + C_2}$$

RESISTANCES IN PARALLEL

$$R_{TOTAL} = \frac{R_1 \times R_2}{R_1 + R_2}$$

BOTTOM VIEWS OF SOCKETS

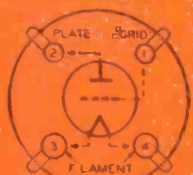

4-PRONG SOCKET
50-201-41-45, 210, 30, 31, ETC

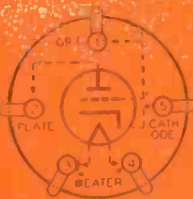

5-PRONG SOCKET
56-46-47-76-27-37
(Cat code is Screen Connection for '47)

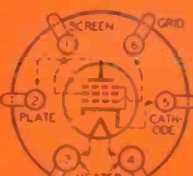

6-PRONG SOCKET
2A3-41-42-43

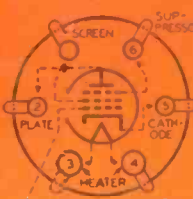

6-GRID-METAL TOP CAP
6-PRONG SOCKET
57-58-6C6-6D6-77-78

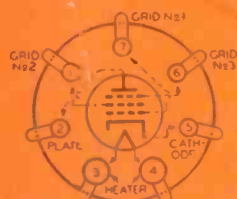

7-PRONG SOCKET 59

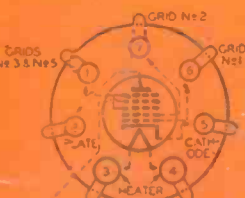

4-GRID-METAL TOP CAP
7-PRONG SOCKET
2A7-6A7

- IN THIS ISSUE -

★ More Grid Drive With Less Excitation

46 Class B Modulator—150 Watts

Battery-Operated Low Power Phone

250-Watt Controlled Carrier Xmtr

5-Meter Receiver With Regenerative R-F



The Illustration Shows the New Amperex HF300 in a Home-Built 600 Watt R-F Amplifier. Complete Operating Details in This Issue.

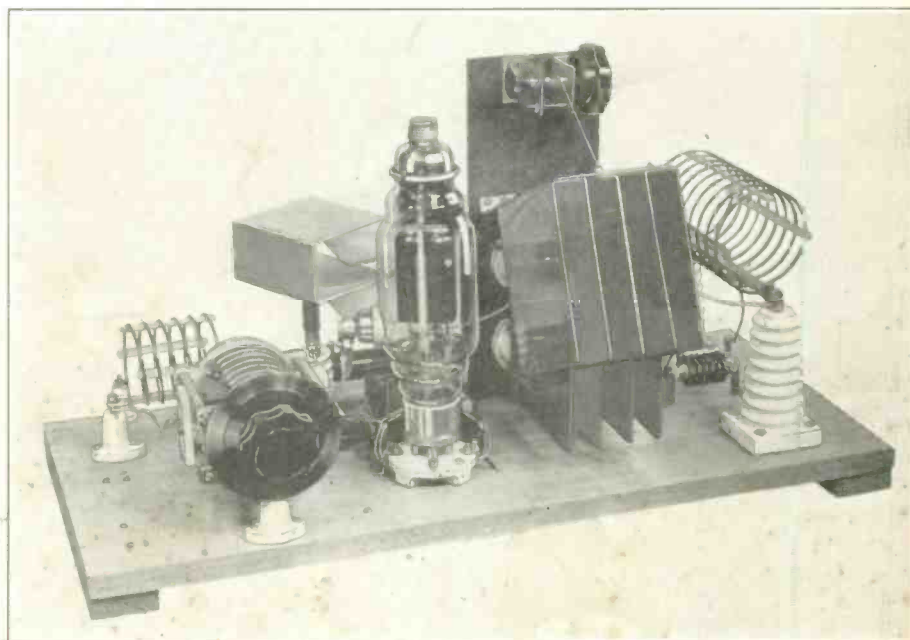

FEATURE ARTICLES BY ...

FRANK C. JONES
R. G. MARTIN

D. B. MCGOWN
FRANCIS CHURCHILL

SUMNER B. YOUNG
HENRY WILLIAMS

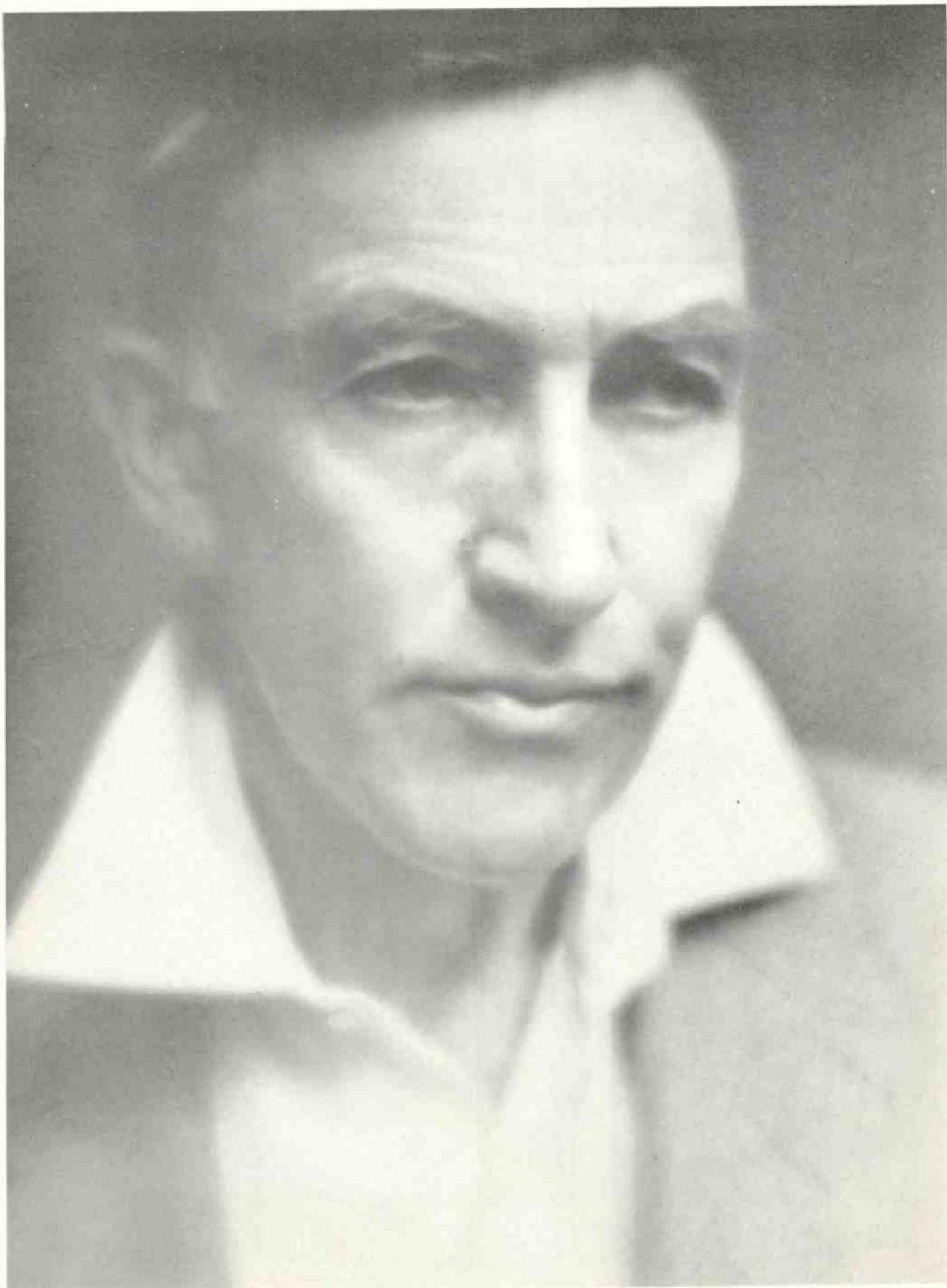

Colonel Clair Foster, W6HM

BRANCH OFFICES:

New York City,
253 W. 128th St.
Tel. MOument 2-2812

Boston,
J. H. Condon,
6 Marlboro St.

Chicago,
C. W. Nelson,
3618 North Bernard St.

RADIO

ESTABLISHED 1917

Reg. U.S. Pat. Off.

A NATIONAL MAGAZINE - PUBLISHED MONTHLY

Publication Offices—Pacific Building, San Francisco, California

H. W. Dickow, Publisher.

D. B. McGown, Technical Editor.

Frank C. Jones, Engineering Editor.

C. C. Anderson, Engineering Draftsman

25c per copy, \$3.00 per year by subscription in the U. S. \$4.00 elsewhere. Send subscriptions to the San Francisco office. Entered as second class matter at the Post Office at San Francisco, California, under the Act of March 3rd, 1879.

Vol. 17

NOVEMBER, 1935

No. 11

"30"—W6HM

COLONEL Clair Foster, W6HM, of Carmel, California, died in Denver, Colorado, on Wednesday, October second, 1935.

He was the most colorful figure in Amateur Radio, and his name was a "household word" in every "Ham Shack."

In all parts of the world, Amateurs will miss him. Those who knew him best will be saddened by the passing of a kindly, gallant and lovable gentleman. Amateurs of all schools of thought will find a common ground in mourning the death of one who was a vigorous and outspoken advocate of their rights and privileges.

It would be presumptuous for me to attempt to write a detailed review of his remarkable career, or to try to express how his friends felt about him. There are others who are better qualified than I.

His admirers sent him everything from fancy "QSL-cards" to African war-clubs and stuffed alligators. The walls of his radio station were loaded with these gifts and mementos, and they overflowed into his garage.

The affectionate regard shown for him by the many Amateurs who came into personal contact with him on the Pacific Coast, was well earned. He was democratic in the best sense of that word. He was a perfect host. His kindness and generosity were proverbial.

He was born in Chicago sixty-six years ago. His early schooling was somewhat unconventional. When in one of the early grades, his teacher forced him to recite a poem before the whole class. While standing before his schoolmates, memory was swallowed up in stage-fright; and the incident made such an impression on him that when he returned home that night, he told his older sister that he was through with that particular school from then on. The characteristic Foster tenacity won out; and for several years his sister took over the task of teaching him the fundamentals of an education. This sister, Emily Foster Day, later became well known as an author.

His father was English, and was a Colonel in the Canadian Army. When the Foster family moved to Chicago, the senior Colonel Foster entered the contracting business.

The old gentleman, a stern disciplinarian, and a man of sound sense, believed in teaching boys a trade. Accordingly, Clair, in his "teens," spent his school vacations working as a mason; and the boy learned this work thoroughly under his father's eye.

While in Chicago, Clair came into contact with his uncle, Dr. Norman Foster, who took a great fancy to him, and urged him to enter the medical school. But when Clair graduated from high school at the age of eighteen, he found that he was more attracted to the contracting business than to professional life.

Once out of high school, his father sent him West to Kansas, where an older brother was in the business of erecting steel bridges.

About this time, buildings of the "sky-scraper" type, consisting of steel frames and masonry walls, came into vogue. Opportunity knocked loudly on the door of an able young man who understood three things: steel, masonry, and men.

At twenty-one, Clair Foster was Superintendent of Construction in charge of the building of the big Illinois Central railroad station on the lake-front in Chicago. It was one of the first large steel-framed buildings in the United States, and it was also among the first few big construction jobs in this country to be carried on right through the cold winter months; and the station went up in record time.

As was natural, two years later the Colonel landed in New York City, where buildings were growing bigger and taller by leaps and bounds. He entered the contracting business there, and was very successful at it. He first took a job as Building Superintendent for the George A. Fuller Company, and was placed in charge of various construction jobs in New York City, Atlanta, Georgia, and Syracuse, New York.

After a few years of this, he used his first savings for an extensive European tour, and this vacation gave him keen enjoyment.

He then became General Superintendent of all construction for the Thompson Starrett Company in New York. This was during the period when many tall buildings were being built on lower Broadway.

Later he became Vice President of the Standard Plunger Elevator Company and Operating Vice President of the Bush Terminal Company, whose warehouse, terminal, and docking facilities, located in Brooklyn, New York, are among the largest in the world.

The Colonel retired from active business in 1914, and spent much of his time on his farm in the Berkshire Hills of Massachusetts. He spent the winters in California, and also passed some of the summer months in his camp on Vancouver Island, at Alberni, British Columbia.

In 1917, he, together with his friend and former business associate, Colonel William Starrett, was called to Washington to assist the War Department in its huge building program. He was given a commission as Major in the Corps of Engineers. Together with Colonel Starrett and Mr. John Donlin, a well-known Labor leader, he served in an advisory capacity in the Council of Defense. This Committee of three worked directly under the Secretary of War and the Assistant Secretary, who had charge of all munitions. The Committee's job was to tell these officials to whom all building and munition contracts should be let; and they also passed judgment on standards to be achieved, and on the ability of men and corporations to perform.

He left active service as a Colonel; and at the time of his death was a Colonel in the Reserve, in the Quartermaster's Corps of the United States Army, many of the war-time activities of the Engineering Corps having been transferred to that Department after the World War. He was instrumental in putting into practical form a scheme of "industrial mobilization" which will enable the United States to produce guns, munitions and supplies more quickly, if we ever go to war again. His post-war organization work covered the Ninth Corps Area of the Army, and was eventually extended to Alaska and the Territory of Hawaii.

Colonel Foster first became interested in Amateur Radio about 1921 or 1922, and his station, W6HM, rapidly became known all over the world. He "worked" every continent, and made hosts of friends.

During 1932 he served as a Director of the American Radio Relay League, Inc., representing the Pacific Division. He always took a lively interest in League affairs.

His radio station brought him many interesting, and happy, hours. A story he told to me last summer is worth passing on to you, because it so clearly reveals the Colonel's characteristic turn of mind:

Some time after the war, the famous German sea-raider, Count Von Luckner, visited the United States on a lecture-tour. He sailed his own ship, which was a "wind-jammer" with only an insignificant auxiliary drive. Arriving at New York, he ordered the vessel through the Panama Canal to the Pacific Coast, and told the Captain to meet him in San Francisco. Throughout the trip, Colonel Foster kept schedules with Count Von Luckner's ship, and a lively exchange of radio correspondence between the Captain, the Colonel, and the Count, began. Contrary winds and bad weather met the ship in the Pacific Ocean, and after a while supplies and food began running low. The Engineer was using oleomargarine on the machinery. The Captain did not air his troubles to the Count, but the Colonel learned of them through the wireless man. When the ship was close to San Francisco, but making very little progress, the Colonel sent a radio to the Captain suggesting that he call a tug. The Captain replied, in courteous but firm words, that he had sailed the seven seas, man and boy, for many years, and had always made port; and would do so without help on the present occasion.

"I said to myself," the Colonel told me: "That Captain is a stubborn cuss, but I'll bet that if a tug showed up near him, he would tell it to heave him a line." The problem was to place the tug near the "wind-jammer" in a tactful manner. The Colonel solved it by telephoning the Count's agent in San Francisco, and telling him that the ship was all out of lubricating oil, and wanted a barrel sent out by tug immediately. The agent asked what particular brand the Captain wanted. Foster told him "Mobile B," which was the first name that happened to come into his head, and the tug set out. It towed the "wind-jammer" safely into port.

Colonel Foster was an ardent believer in the future of Amateur Radio, and he wanted the "Hams" to take an active interest in our League. He wanted us to have our "place in the sun," and was the first to tell us not to be overawed by the opposition, but to stand up to them and fight.

That lesson, well learned and intelligently applied, may well be our salvation.

We should honor him for teaching it to us.

SUMNER B. YOUNG, W9HCC

Colonel Foster's Last Editorial

EDITOR'S NOTE:—

Numerous are the requests for informative facts which give the reason why the ARRL is not now an organization composed solely of licensed radio amateurs. An Eastern group of amateurs asked the Colonel to prepare an address for a radio broadcast, but the information was to have been of a "neutral" nature.

The letter reproduced below was written by the Colonel only a few days before his death. It was never mailed to the W9 who asked for the information.

● I doubt if I could provide you with anything "neutral" for your broadcasts. I'm not a neutral person. I have to be on one side or the other, without any qualifications, and when I'm wrong I just take the consequences. I state whatever my observation leads me to believe and leave it up to you fellows to pass judgment. Perhaps you can read what I have said in "RADIO" and neutralize it to suit your own purposes when it sounds too hot to you. I'm often pretty raw, I know; but it may convey something to you if I tell you I have been saying what I think for many years—things that are libellous if untrue—without ever ONCE being yanked into court for it. If anyone at Hartford would say of me just ONE of the many things I have said of him I'd have him in court so quick his head would swim—if I knew it were not true.

The ARRL administration at Hartford is a racket that has been conducted for years for the benefit of a few insiders—mostly for Warner. I first got onto it back in 1926, two years after I got into ham radio, but until "RADIO" went ham there was no medium of wide circulation in which I could expose it. QST, as you know, is closed to anyone who doesn't play Warner's game. I'm familiar with rackets of many kinds; the ear-marks of them are unmistakable wherever they exist. Business is full of them. In that line I have at times found MYSELF mixed up in them. In sports, rackets are rampant—tennis, golf, dog-exhibiting, "amateur" athletics, ham radio. There never was a fraternal, or similar, association that gave promise of "making money" that some insiders didn't try to turn into a racket for the



W6HM—Amateur Radio's Watch-Dog

benefit of a favored few. A group tried it even with the National Geographic Society once upon a time. The Hartford racket has carried on for more years than most of them—due to the inexperience of the rank and file of amateur radio.

Read again "The Birth of a Racket" on page 4 of "RADIO" for May, 1935. I doubt if I can make any plainer how and when the racket started in the ARRL. There were many subscribers to QST who were not members of the ARRL. Warner's contract gave him nothing out of these yearly subscriptions but did give him 25 cents out of each yearly paid dues of members. The members owned all the assets of the ARRL, including the business of publishing QST. There was no lawful way in which the owners could be forced to share their ownership. This could be done legally ONLY by the individual consent of all owners. Their consent was never obtained; it wasn't even asked.

Throughout the years that have intervened you will find no reference to this scheme. The subject was avoided as if it were a plague—as indeed it was. One would think that so momentous an occasion as turning the ARRL into a hodge-podge of membership far removed from amateurism would have demanded some future reference as to how the plan had worked out. You will find no such reference. The whole subject was so well buried that I'll wager you can't find even a director aside from Maxim who knew the facts until "RADIO" exposed them a year ago. Now, I ask you, if such a radical move had been honest and honestly conceived, would there have been any need for all this concealment! The whole policy at headquarters with respect to any move that may be ethically questionable has been to inter the subject promptly, cover it up, and then if it still excites discussion provide new alibis.

Which reminds me of the man who called up the veterinary one night to say that his cat had eaten something poisonous. He wanted the vet to come over immediately. The vet, thinking the man had said "calf", replied that he couldn't come that night but to administer 4 ounces of castor oil and that he would be over in the morning. The next morning the vet called up to find out how the animal was getting along. "Oh, he's alright", said the man. "He is out in the yard now. And he has six of his friends out there helping him—two digging, two covering up and two hunting for new locations."

Now, doesn't it strike you as significant that after all the exposure of this scheme not ONE of the instigators of it has come forward with an attempt to refute the charges? If you yourself were in the position of any of these men and you felt you had been falsely accused would YOU have sat quietly and permitted the charges to go unchallenged? If your conscience was clear you bet you wouldn't! Can you imagine yourself the president of a corporation and the man responsible for an act that had violated the ownership rights of the members, that had transgressed the fundamental principle of the corporation, that had unwarrantedly taken money out of the treasury and put it in the pockets of one man, and still see yourself making no move to clear your skirts?

You may say—as many do—"Oh, this is ancient history!" No it isn't. It is present history and of immediate concern for the effects of the act are poignantly present today. Moreover, every man's reputation for square-dealing is ALWAYS present history with those whose business affairs come in contact with him. In this case it is most certainly present history for the three men involved in the act are TODAY in control of the ARRL because they occupy today the offices they held when the act was committed and because they constitute the majority of the Executive Committee that today controls the administration of the ARRL.

This racket will go the way of all rackets. It will end SOMETIME for the simple reason that evil invariably provides the means for its own destruction. The pity of it is that through this particular racket the amateurs have suffered woefully and are likely to suffer more before the situation is cleaned up. The racketeers in this instance have the edge on the reformers, for they have a tight hold on the machinery of the ARRL, its records, its money and its mouthpiece. However, now that it is being exposed its finish will not be long in arriving. When the people are informed, a racket is on its way out. That is the job of "RADIO"—to inform. "RADIO" does not conceive itself as the reformer; the reformers must be the amateurs themselves. "RADIO" and QST are diametrically opposed in their editorial policies. QST seeks to CONVINCe; "RADIO" aims to INFORM. QST tries to impose upon its readers certain conclusions previously arrived at by its editor. "RADIO" aims to report observable facts and to permit its readers to draw their own conclusions. QST treats its readers as if they were a congregation of oafs; "RADIO" addresses its remarks to readers of intelligence and discrimination. "RADIO" has nothing to hide, while with QST the editorial policy is continually one of alibing, covering-up and distorting the truth.

Clair Foster, W6HM.

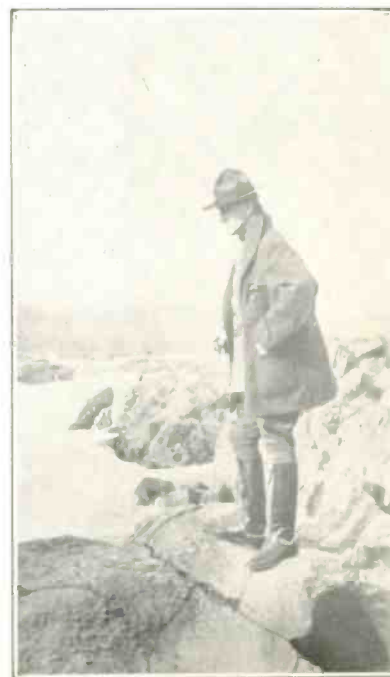

W6HM—As a Colonel in the U. S. Army

What the Amateur "Leaders" Are Doing!

Shuffling The Cities

● You have all heard of the "card-sharp" who would never bet on a horse-race "because he couldn't shuffle the horses." Well, here's a modern manifestation of the same attitude:

The Warner machine doesn't like the idea of allowing the amateurs to hold conventions unless it can "shuffle the cities", and decree where these conventions shall be held.

Conventions in "anti-Warner hot-spots" such as Minneapolis, various California cities, etc., have had an unpleasant tendency to arouse the licensed amateurs of the United States to a realization of the way in which their League has been allowed to degenerate into a mere publishing business, and to stir them to anger over the way in which legislative and political affairs have been mis-handled by our "authorized representatives."

Headquarters may be "dumb" in some ways; but where the jobs of the "insiders" are at stake, they think long and hard. And every once in a while they turn out a pretty brilliant idea to save their hides. Their latest scheme of this type was disclosed to the amateurs of Spokane, Washington, by rotund, politically-minded Warner henchman DeSoto during his "contact-trip" there in late August of this year of grace.

He announced that hereafter the amateurs will convene in the place where the Director of the particular Division chooses.

Yes, the amateurs can "suggest" the names of cities where they "desire" to convene; but that's as far as they can "stick their oars in".

With more "Warner men" ("W-Men" for short) on the Board than Progressives (as presently constituted), a majority of the directors undoubtedly will be docile, and will take their orders directly from West Hartford, as to where and when any given convention shall be held. And in the majority of Divisions, "peace" will then prevail. No longer can a convention be staged in a city which is "anti-Warner". No longer can the "W-Men" be chided, ridiculed and embarrassed by the more mature amateurs who long ago drew away from Warner and all his works, because they saw what Warner was actually doing to their League, instead of what Warner wanted them to believe.

The Spokane amateurs sat quietly through the DeSoto announcement. The talking started after DeSoto left for home. Indignation is now mounting, as the amateurs begin to realize what is back of the proposal of the well-paid Headquarters Staff back in Connecticut.

Resentment may well reach such a pitch that the "hams" will stay away from conventions held at places not of their choosing. This boycotting of such conventions strikes us as being the proper answer to coercion of this type.

Slowly, but surely, the Warner machine is grinding itself to pieces by mistakes like this.

It should at least learn to realize that the "hams" are not as dumb as DeSoto and the rest of the "W-Men" think they are.

"IS THAT OFFICIAL?"

ON Page 11 of the October, 1935, "QST," Mr. Warner says that our "authorized representatives" emerged in triumph from the Four Hoover Conferences (where they DID voluntarily relinquish most of our territory under the 1912 Act for commercial development) with "a series of wide and adequate bands which represented all that it . . ." (he means Amateur Radio) . . . "AND SUCCEEDING GENERATIONS OF AMATEURS COULD EVER USE! . . ."

He emphasizes this idea again on Page 12 of that same issue, by saying that it was the League's job (during the Hoover Conferences) to get "plenty of frequencies for ourselves;" and his next sentence says: "We got thoroughly adequate assignments."

Well, you gotta hand it to Warner. He's taken the one and only position left open for him to take. If he's driven out of this one, there's no place else to go. Man's capacity to concoct alibis at short notice can be stretched no farther.

IN reaching this position, however, he has made a statement of IMMENSE SIGNIFICANCE.

Obviously, his words will be taken as an official pronouncement on behalf of the American Radio Relay League, Inc., that bands of "Hoover width" REPRESENT ABSOLUTELY ALL THAT WE AMATEURS SHOULD EVER HAVE, AND THAT SUCH BANDS, IF WE NOW HAD THEM, WOULD BE ADEQUATE FOR ALL TIME.

Now, IS THAT OFFICIAL?

DID the Board of Directors authorize Mr. Warner to publish any statement so obviously capable of such interpretation?

If they did, why do they think it wise to come out with such a proposition at a time like this?

Looking into the future, and presuming to read it with such accuracy, implies the possession of powers of supernatural scope. And announcement of such conclusions to the world in general should be made only if and when there is some advantage to be gained.

If we were on the "Cairo Committee," we would consider Mr. Warner's Editorial on Pages 7 and 8 of the June, 1935, "QST" (glorifying the single-signal super as an instrument tending to make our present bands adequate) extremely ill-advised; but that June Editorial isn't a patch on this October pronouncement.

If we were sitting on that Committee, and Warner made a "crack" like that, **unauthorized**, we would never rest until he was out of office.

But perhaps the Directors are content, even now, simply to go through the motions of directing, and let Warner run the League. Habits, you know, are awfully hard to break.

We doubt if there are many individuals among the 46,000-odd Licensed Radio Amateurs in the United States who will agree that our "Hoover bands" were adequate at the time, or that they would be adequate for all time, if we could get them back.

If the League thinks so, that's one thing. If this is just so much more "Warner wind," that's another.

Again we ask:

IS THAT OCTOBER EDITORIAL OFFICIAL?

1000 Watts at 5 Meters with Amperex Carbon Anode Tubes

Specially Designed for Ultra High Frequency Operation

RATING AND DATA

HF200

FILAMENT:

Voltage _____ 10-11 Volts
Current _____ 3.4 Amps.

GEOMETRIC CHARACTERISTICS:

Amplification Constant _____ 18
Inter-Electrode Capacities:
Grid to Plate _____ 5.8 MMF.
Grid to Filament _____ 5.2 MMF.
Plate to Filament _____ 1.2 MMF.

MUTUAL CONDUCTANCE 5000

at Plate Current of _____ 150 MA.

MAXIMUM OPERATING RATINGS: when used as Class C Oscillator or Power Amplifier at frequency of 60 megacycles.

Allowable Plate Dissipation _____ 150 Watts

Plate Voltage _____ 2500 V. A. C.

Plate Current _____ 200 MA.

D. C. Grid Current _____ 60 MA.

D. C. Grid Bias Voltage _____ 350 VOLTS

Attainable Plate Power Output _____ 250 to

_____ 350 WATTS

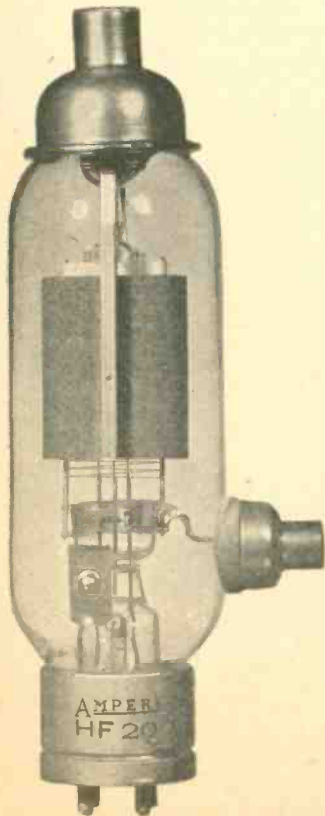

SUCH are the design characteristics and efficiency of the Amperex HF300 Tubes that in suitably designed circuits a pair of them will deliver a 1000 Watt Plate Power Output at 5 meters. Their remarkable performance has been made possible by the design characteristic which gives these tubes the distinct advantage of possessing the highest ratio of Transconductance to Interelectrode Capacitance yet attained in any tube. This characteristic in combination with their high mu reduces the requirements for grid excitation to a minimum.

These new Amperex tubes are proportioned along conventional lines. There is nothing freakish in their structure or appearance. In their design is incorporated the latest engineering practice and knowledge of ultra-high frequency operation.

Such has been the successful acceptance of the Amperex Ultra-High Frequency Tubes that some of the major competitive manufacturers have copied in detail their design and structure.

A partial list of Amperex tubes suitable for Amateur and Experimental work is listed below:

Watt Plate Power Output

HF300 500	\$50.00
HF200 400	24.50
211-H 175	17.50
203-H 175	17.50
211-C 150	17.50
211-D 150	15.00
830-B 50	10.00
801 25	3.25
872-A Mercury Rectifier.....	17.50
866-A Mercury Rectifier.....	5.00

AMPEREX

Electronic Products, Inc.

79 Washington Street Brooklyn, N. Y.

West Coast Representatives

C. R. STRASSNER
1341 So. Hope St., Los Angeles, Calif.

R. C. JAMES, Jr.
Northwestern Agencies
Third Ave. & Vine St., Seattle, Wash.

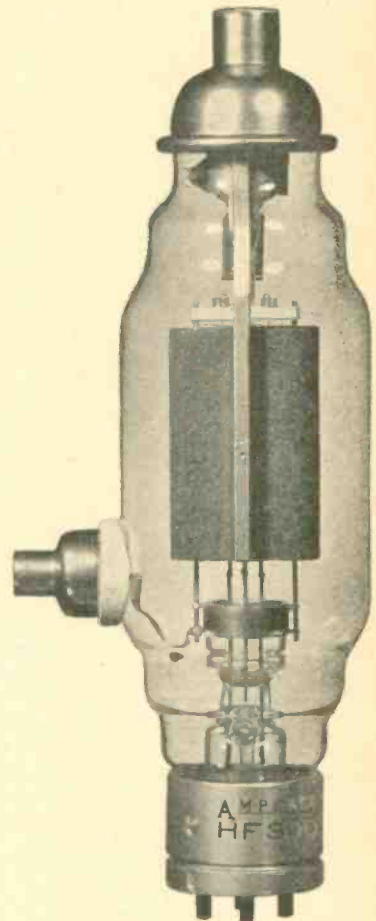

RATING AND DATA

HF300

FILAMENT:

Voltage _____ 11-12 VOLTS
Current _____ 4 AMPS.

GEOMETRIC CHARACTERISTICS:

Amplification Constant _____ 23
Inter-Electrode Capacities:
Grid to Plate _____ 6.5 MMF.
Grid to Filament _____ 6.0 MMF.
Plate to Filament _____ 1.4 MMF.

MUTUAL CONDUCTANCE 5600

at Plate Current of _____ 150 MA.

MAXIMUM OPERATING RATINGS: when used as Class C Oscillator or Power Amplifier at frequency of 60 megacycles.

Allowable Plate Dissipation _____ 200 WATTS

Plate Voltage _____ 3000 V. A. C.

Plate Current _____ 275 MA.

D. C. Grid Current _____ 75 MA.

D. C. Grid Bias Voltage _____ 400 VOLTS

Attainable Plate Power Output _____ 400 to

_____ 600 WATTS

A 75 Watt Modulator Using Four Type 46 Tubes in the Final

More Watts for Fewer Dollars

By D. B. McGOWN

● More than 75 watts of audio output is supplied by the unit here shown. This power is sufficient to plate-modulate a 211 or 203A operating at 1000 volts with 150 to 160 MA of plate current. Another RF combination could use a pair of Class C 800s at 1000 volts and 150 or 160 MA. Still another Class C stage would be one which uses push-pull parallel 10s or 801s at 600 volts and 250 MA of plate current. The modulator here shown is economical for modulating an input of at least 150 watts, which means about a 100 watt carrier capable of 100 per cent modulation.

The advantage of using four 46s, rather than a pair of 801 tubes in this Class B audio circuit, is in the lower cost. No C bias supply is needed with 46s, a cheaper power supply can be used, and the tube cost is greatly reduced. The output of either tube line-up is about the same.

A pair of 46s in the unit here shown can be used to speech-modulate an input of about 80 watts to a Class C stage. The husky Class B output transformer is an oversize unit designed for this purpose and its physical size is no larger than one used for a pair of 10s or 801s. The Class B input is designed for working out of a pair of 2A3 tubes in push-pull. Apparently the turns ratio is not very critical on either transformer if the units are designed for this general type of service. For example, the input transformer could be one designed for operating into 203As from push-pull 2A3s. Taps on the output transformer take care of various Class C amplifier plate loads.

The 20,000 ohm grid resistors across the input Class B transformer provide a more constant load to the driver stage. The .001, 1000 volt, mica condensers across each grid to ground tend to prevent a high-frequency oscillation under conditions of high input. In some cases, 40 ohm 10-watt resistors must be used in series with the plate leads in order to prevent a parasitic oscillation. In this particular unit these plate resistors were not needed, but it is usually a good plan to use the plate resistors because this form of trouble shows up only on speech, not under steady tone tests or no-input tests. A monitor test on speech modulation of a radio transmitter will usually show up this trouble in the form of raspy sounding speech quality. The resistors and grid shunt condensers will usually cure the trouble.

The driver stage uses a pair of 2A3s, although tests have shown that a pair of 45s work almost as well. Sufficient audio driver output can be obtained without using fixed grid bias and self-bias is therefore used to eliminate the need of an external C bias supply.

The 2A3s are driven by a 57, connected as a triode, working into a 1-to-1-each-side interstage audio transformer. Another 57 tube connected as a triode is resistance coupled to it, providing sufficient overall gain to work out of a highly-damped double-button carbon mike. A pre-amplifier and condenser, dynamic, or ribbon mike could be used to work into the input transformer shown.

If a diaphragm type crystal mike is used the input transformer should be eliminated and the first 57 tube connected as a high-gain pentode with a 250,000 ohm plate resistor, 2 megohm series screen resistor and

.1 mfd. by-pass, and a 3500 ohm cathode resistor. The input should be shunted with a 3 or 5 megohm resistor, and the input should be entirely shielded. The volume control should then be placed in the grid circuit of the 57 triode connected tube.

In the unit shown, it was necessary to ground the cases of all transformers, as well

in order to prevent RF feedback or hum pick-up.

The power supply uses a pair of 83V or 83 tubes, each connected as a half-wave rectifier. This connection prevents flash-over in the stem and allows the RMs voltage to be raised over its usual safe value. Some 83V tubes break down, but in general they seem to be more satisfactory than 83 tubes. 5Z3s or 80s will stand more AC voltage input, but they do not give as good voltage regulation. Because the plates are paralleled, a pair of

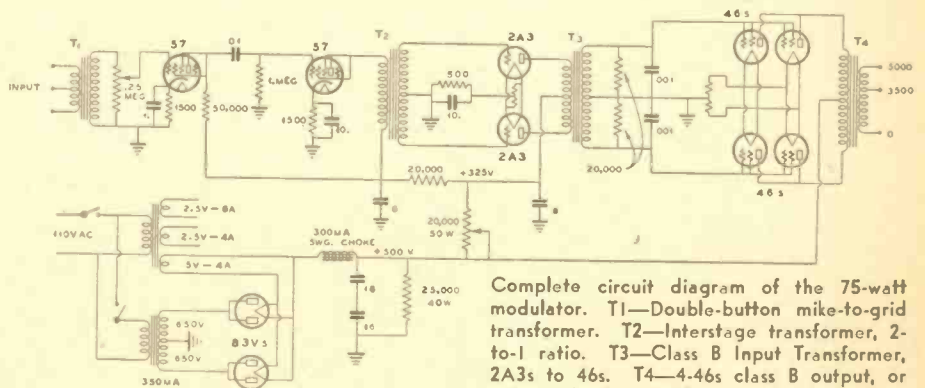
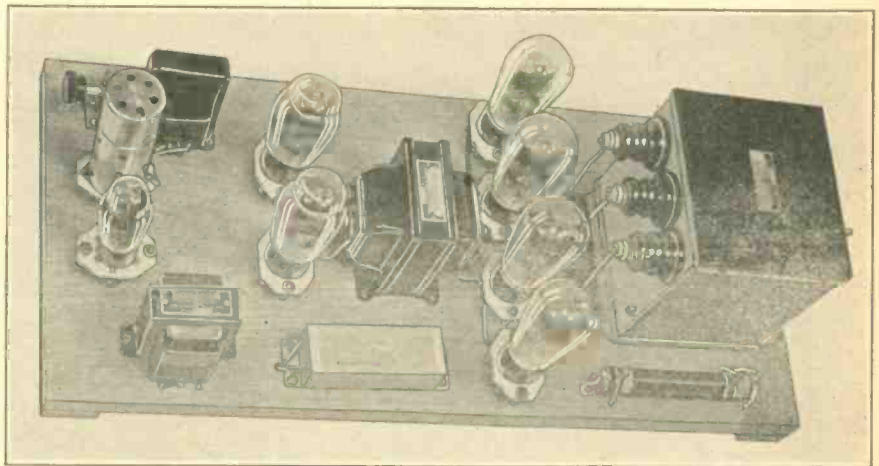

Complete circuit diagram of the 75-watt modulator. T1—Double-button mike-to-grid transformer. T2—Interstage transformer, 2-to-1 ratio. T3—Class B Input Transformer, 2A3s to 46s. T4—4-46s class B output, or tapped 210 class B output transformer.

as the volume control mounting bracket. Either the center or one side of the input transformer must also be grounded in order to prevent a high audio-frequency squeal. Reversal of one transformer winding sometimes helps in such cases. Often the input transformer and tube must be double shielded

5Z3s can be used in this power supply for speech work.

The entire power supply uses only one power transformer and one choke, plus a three winding filament transformer. The high voltage transformer which should deliver 500 volts DC at the output of the filter under load, has no filament windings, consequently the primary circuit line switch can be turned on after all filaments or heaters are warmed up, thus greatly increasing a rectifier and amplifier tube life. The transformer should have a rating of about 600 or 650 volts RMS at about 300 MA because the AC load is heavy, running as high as 350 MA. The swinging choke should also be large, and capable of handling over 300 MA of DC. Two 16 mfd. condensers of the 600 volt peak rating, connected in series, provide 8 mfd. for the by-pass and filter condenser. This condenser should have at least 6 mfd. in

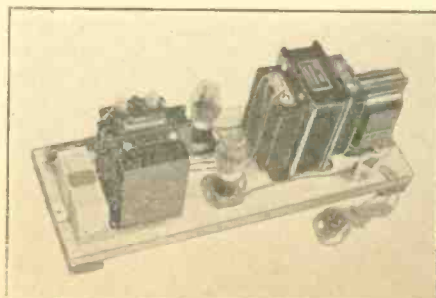

Power Supply for 75-Watt Modulator.

(Continued on page 36)

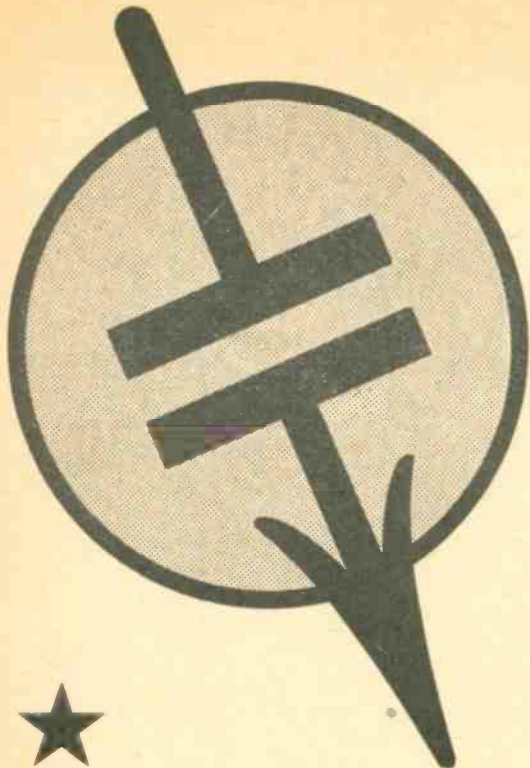

What Is the Easiest Circuit to Drive?

... The answer is here given by Frank C. Jones

... An important controversy is decided in favor of the single-section condenser in a single-ended r-f amplifier.

● The problem of obtaining sufficient grid excitation is of utmost importance to the amateur. There is a saving in buffer power, or the possible elimination of one buffer stage in a typical amateur transmitter, if the RF amplifier can be equally well driven with less grid current.

Mr. H. E. Preston, W8CSE, found that he could more easily drive a final stage which used a by-passed coil center tap, than the same amplifier with a split-stator tuning condenser. His findings seemed to check in other stations. Exhaustive tests were made in the laboratory of "RADIO" on two different sets, operating on 20 meters. One set used an Eimac 50T in the final amplifier, the other used an Amperex HF300 with maximum outputs in the tests of 150 and 600 watts respectively.

The circuits are shown in Fig. 1a and Fig. 1b, both with plate neutralization. Fig. 1b has been the standard circuit because of its ability to maintain neutralization for coil changes—but the tests indicate that it takes approximately twice as much grid excitation driving power as the circuit of Fig. 1a. Figs. 2a and 2b are the equivalent circuits wherein the inter-electrode capacities are considered. The grid-to-filament, and the tuned grid circuit, need not be considered in the circuit balance.

Several effects were noted when changing over from circuit Fig. 1b to 1a, and the results were identical in both transmitters. The neutralizing condenser was always set for a lower capacity in Fig. 1b, and the grid tuning condenser was set to a slightly higher capacity for resonance. The AC grid current under load conditions dropped much more in the split-stator condenser circuit than in the other, in comparison to no plate voltage condition. In fact, the grid current increased in some cases under load for the circuit of Fig. 1a, even though the neutralization and shielding was very good. This may have been due to a decrease in the grid input impedance under conditions of applied plate voltage. In the case of Fig. 1b the grid current always dropped when plate voltage and load were applied, usually at the ratio of two-to-one.

In the 50T transmitter, an 801 was used as a buffer. Plate current readings, and the

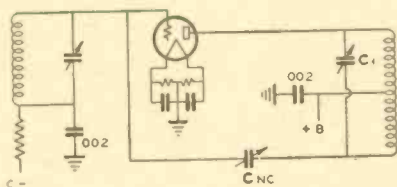

FIG. 1A

This circuit is easier to drive than one in which a split-stator condenser is used.

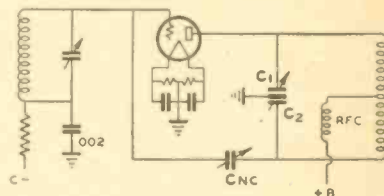

FIG. 1B

This circuit requires twice as much grid drive as the circuit in Fig. 1A.

grid and plate current of the 50T and the output RF power were noted for different degrees of excitation to the 50T and to the 801. The circuits of both Figs. 1a and 1b were tested with all circuits in resonance, re-neutralized for each system. It was found that over a range of DC grid current to the 50T of from 2½ MA to 20 MA (grid-leak plus 135 volts of C battery bias), the output was exactly the same in either circuit for

coupling adjustments. The plate current was from 1½ to 2 times as great for the split-stator connection in the 50T—that is, Fig. 1a only loaded the buffer about one-half as much as Fig. 1b, over the entire range of inputs tested, up to saturation. Increasing the coupling to the 801 circuit until its plate current was at the same value for either circuit, gave nearly twice as much grid current into the final stage under load with a

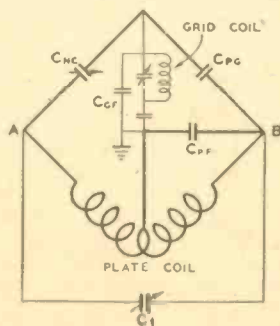

FIG. 2A

equal grid currents. The plate current and RF load power were identical when the load coupling was slightly readjusted for equal plate currents and equal grid currents in either circuit. The coupling to the load had to be slightly greater in Fig. 1a than in Fig. 1b. This also checks in the higher power HF300 RF amplifier circuit.

The interesting point was found in the 801 plate current readings and in the link

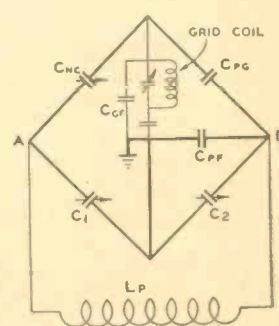

FIG. 2B

corresponding increase in carrier output. Several pages of data were taken on these effects, always carefully checked, from which these conclusions were drawn.

In a given case with the best link coupling adjustments in both circuits between the 801 and 50T, the grid current was always 1½ to 2 times as great in Fig. 1a as in Fig. 1b which means that there was greater output from the 50T up to the point of grid current

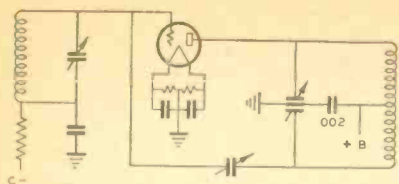

FIG 3

Here the tank coil is tuned with a split-stator condenser. The center of the coil is by-passed to ground. This circuit is slightly easier to drive than the circuit shown in Fig. 1A.

saturation. A practical saving would result from the use of a 2A3 at 400 volts supply, as against an 801 at 600 volt supply as a buffer stage for the 50T operating at about 1400 volts plate potential. Or, the 50T could be operated at 2500 or 3000 volts with an 801 buffer in Fig. 1a but with only 1500 volts or so in Fig. 1b, due to lack of grid excitation in the latter case.

Other practical examples are a 46 driving a 10, or a 10 doubler driving a 203A on 20 meters. The circuit of Fig. 1a will work, whereas Fig. 1b will be shy of grid excitation, resulting in low output and excessive tube heating. Some slight re-neutralizing is necessary when changing bands with the circuit of Fig. 1a. A practical solution of this difficulty is in the use of a split-stator condenser with rotor grounded and a symmetrical circuit layout with the plate coil center-tapped exactly, and by-passed to the rotor with a .002 high-voltage mica condenser. This circuit was also tried, as shown in Fig. 3, and it was found to drive about 5 to 10 per cent easier than Fig. 1a. It worked fine in the set using a 50T, but not so well in the case of the HF300, due to longer leads and non-symmetrical layout of parts. By tapping the coil at its node, slightly off-center in some layouts, Fig. 3 would probably be satisfactory if only a portion of a turn of the coil was off center.

Referring to Figs. 2a and 2b, the reason can be seen for less neutralizing capacity in Fig. 2b, which corresponds to Fig. 1b. Considering the Wheatstone bridge for balance:

$$\frac{C_{NC}}{C_{PG}} = \frac{C_1}{C_2 + C_{PF}}$$

where $C_1 = C_2$ as the two halves of the split-stator condenser. From this it can be seen that C_{NC} is always less than the tube plate-to-grid capacity C_{PG} by the ratio of the tuning capacity in either arm to this capacity shunted by the plate to filament capacity C_{PF} . For

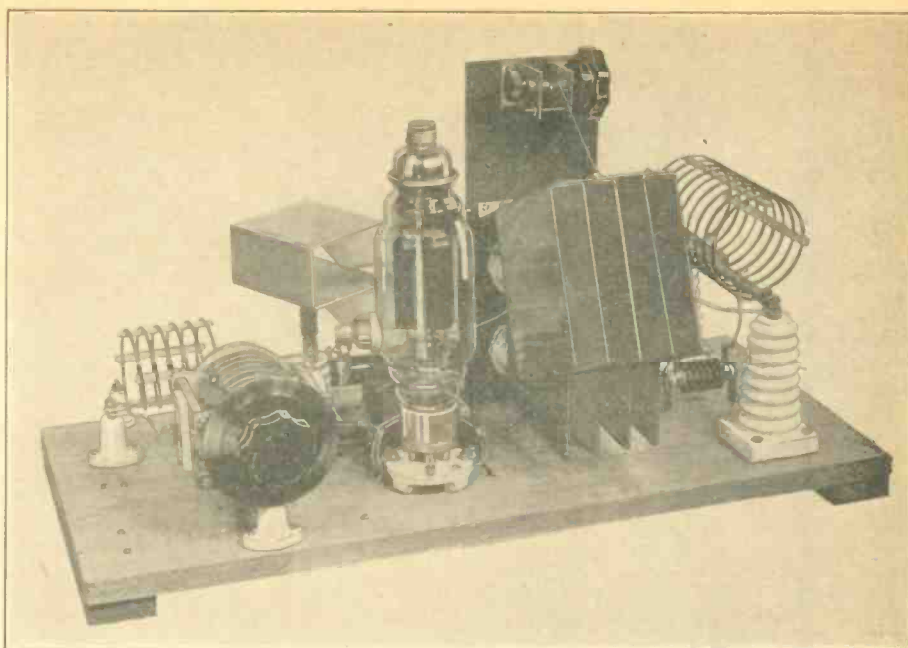

A home built high power final amplifier in which the new HF300 is used. Constructional details for building the tank condenser have been published in recent issues.

exact neutralization of Fig. 1b, a small fixed capacity equal to C_{PF} , under operating conditions, would have to be connected from the plate coil side of the neutralizing condenser C_{NC} to ground.

The same holds true for Fig. 1a, and if this small condenser of a few mmfd. is used (depending upon the tube used), coil changes for different bands could be made without having to re-neutralize. This would put a capacity equal to C_{PF} from A to ground in Fig. 2a and result in a perfectly balanced reactive bridge circuit, assuming a symmetrical layout with equal length of leads to the tube and C_{NC} and a center-tapped plate coil. In practice this is not difficult to do, since the rotor of a single section condenser has more capacity to ground or shields than the stator has; consequently it should be connected to the C_{NC} side of the plate tank circuit. A small grounded aluminum sheet, bent up near the rotor end mounting plate, could be used as an added capacity to ground. In the circuit of Fig. 1a both sides of the tuning condenser are hot with RF and an insulated shaft must therefore be connected to the tuning dial.

The antenna load and the ratio of C to L in the tank circuits were such as to provide

a Q of at least 5, and in some cases 10. The split-stator condenser circuit seemed to have a slightly greater impedance for a given set of conditions, which may partially explain the difference in ease of grid excitation drive. A lower plate impedance in a RF stage will allow easier grid driving conditions. The impedance of a tuned circuit can be calculated for the resonant frequency, but in this case the impressed voltage on it is present only for a portion of a RF cycle and is a complex structure, not a sine wave. The circuit is not resonant to all of the impressed energy. Grounding the center-point of the plate coil may have such an effect on the harmonics and this plate surge of power that the grid impedance is lowered.

The DC grid current without plate voltage is the same for either Fig. 1a or Fig. 1b, showing that the reason lies in the change of tube characteristics under load conditions. The main point to consider is that under actual working conditions the circuit of Fig. 1a is nearly twice as easy to drive from the buffer stage as the circuit in Fig. 1b. The split-stator condensers used were rated at 40 and 50 mmfd. per section, and in these tests they were used by floating the rotors, as in the case of testing Fig. 1a.

600 Watt Output Amplifier

• The illustration at the top of the page shows the 600 watt amplifier described in this article.

• Here is a high power amplifier that puts out a carrier of over 600 watts on 20 meters, using a single Amperex HF300 tube. This amplifier can be driven by the 20 meter transmitter previously described in these pages; the unit consisting of a 6A6 oscillator-doubler tube to drive an 801 at 600 volt plate supply, which in turn drives a 50T tube with only 1400 volts plate supply. The driver supplies more than ample excitation for the HF300 tube for inputs of from 800 to 1000 watts. Above 800 watts input, at 2700 volts

plate supply, the HF300 plate begins to show color. This tube makes an effective amplifier for outputs of from 500 to 700 watts at 20 meters. Its efficiency in this range is high because the HF300 was primarily designed for 6 meter oscillator circuits used in diathermy equipment.

The HF300 is designed to operate with plate currents up to 275 MA at voltages between 2000 and 3000. The filament takes 4 amperes at between 11 and 12 volts and the plate dissipation is rated at 200 watts. Its mu is 23, and its mutual conductance is rated at 5600. The plate-to-grid capacity is 6.5 mmfd., the plate-to-filament capacity 1.4, and the grid-to-filament capacity is 6 mmfd.

From this data it can be seen that twice cut-off bias at 2700 volt plate supply would be 235 volts. Bias is easily obtained with a 10,000 ohm leak, and fairly easy to obtain with a 5000 ohm grid leak using a 50T as a driver with 140 watts input. The DC grid current under load ran between 35 and 60 MA for grid-leak values of from 10,000 to 5000 ohms with various degrees of antenna loading.

(Continued on page 26)



The HF 300

A Mobile Transmitter for the Ultra-High Frequencies*

By W. C. TINUS

● The assignment of certain ultra-high frequency channels for police service has permitted many cities to take advantage of the desirable features of these very high frequencies. While some municipalities feel that one-way transmission is entirely adequate, others prefer two-way communication, which permits officers in patrol cars to talk to headquarters as well as receive announcements and instructions from them. For two-way communication ultra-high frequencies are particularly favorable because the transmitting antennas required are small and can, therefore, be conveniently erected on the patrol cars. To meet the demand for this two-way service, Bell Telephone Laboratories have developed a small radio transmitter for operation at any frequency in the range from 30 to 42 megacycles.

This new radio transmitter, known as the 18A, is designed to deliver 5 watts of high-frequency carrier power which tests have

shown to be adequate for the service intended. The apparatus is mounted on a metal chassis which slides into a cabinet only eleven inches long, seven inches high, and six and one-half inches deep. The complete transmitter weighs under twenty pounds, and since it requires no attention in ordinary operation, it is usually mounted in the trunk or other compartment at the rear of the car. The only controls on the front of the transmitter are four tuning adjustments, which are turned to their proper settings with a screwdriver when the set is installed and require no further attention from the person operating the transmitter.

When the transmitter is used on patrol cars all power is derived from the six-volt battery charged by the car generator. Tube filaments are supplied directly from the battery, while plate and grid potentials are ob-

tained from a 300-volt dynamotor driven in turn by the battery.

The transmitter is crystal controlled and maintains its frequency well within .025% of the assigned value. Temperature control is provided, but the crystal is of a new type of cut and requires only that the temperature be kept above 0° C. All of the four tubes used in the transmitter are pentodes of the Western Electric 306A type. One is an oscillator, which feeds a harmonic generator, which in turn excites a modulating amplifier at output frequency. The fourth tube is an audio amplifier, the output voltage of which is super-imposed on the plate and screen circuits of the modulating amplifier. The compact arrangement of the apparatus is indicated by Figure 1, which shows a rear view of the chassis removed from the cabinet.

A simplified schematic of the circuit is shown in Figure 3. As may be seen in this diagram four tuned circuits are employed; two of these are in the output circuit of the

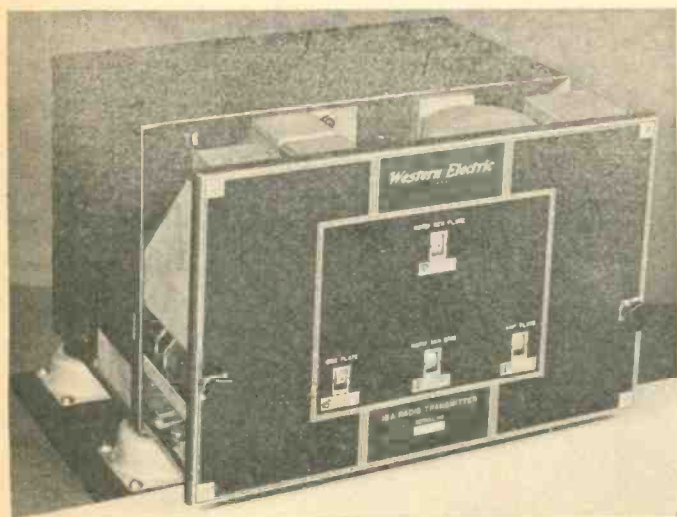

Front view of the Western Electric 18A.



FIG. 1—Rear view of the chassis of the 18A Radio Transmitter. The harmonic generator tube is inverted to shorten the leads.

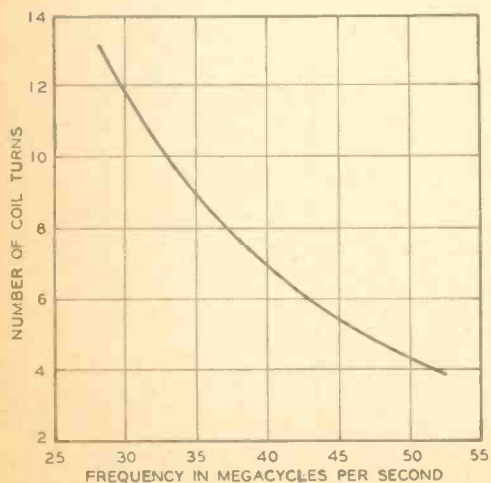
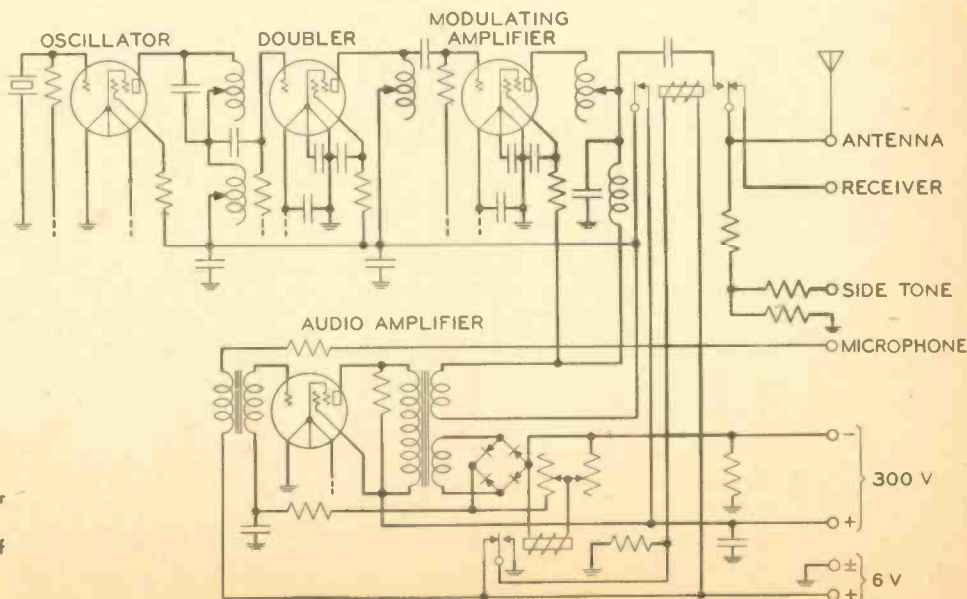

FIG. 2 (above)—Tuning adjustment chart for the amplifier plate tuning coil.

FIG. 3 (right)—Simplified schematic circuit of the 18A Radio Transmitter.



*Courtesy Bell Laboratories "Record".

oscillator tube, and one each in the output circuits of the harmonic generator and modulating amplifier. At very high frequencies both the inductance and capacitance required for such tuned circuits become quite small. In fact, the stray capacity due to the wiring and the tube elements alone is more than ample for efficient circuits. Since these stray capacities are fixed, it is desirable to tune these circuits by adjusting the inductance of the coils rather than by adding more capacity to the transmitter in the form of a variable condenser.

To provide such tuning for the 18A Transmitter presented quite a problem because the usual methods of building continuously variable inductances become impractical when applied to coils of the small size required for ultra-high frequencies. To overcome these practical difficulties, the arrangement shown in Figure 4, which is a view of the under side of the chassis, has been developed. The bare wire forming the inductance is wound on an insulating cylinder which can be rotated by a screwdriver from the front of the panel. A connection to one end of the coil is made through one of the bearings, and the other connection is made through a small grooved wheel which rides on the turns of the coil. This small contact wheel is free to rotate on a shaft parallel to the coil, and rolls along the turns as the coil is rotated one way or the other. A light spring holds the contact wheel against the coil with even pressure, thus insuring a good and steady contact at all times.

Tuning is simplified by the provision of four charts showing the number of turns of each coil that should be in the circuit for any desired frequency. One of the charts is shown in Figure 2. A small dial immediately above each adjustment, evident in the illustration at the head of this article, indicates the number of turns in the circuit. The first coil in the plate circuit of the oscillator tube is set for the crystal frequency and causes the crystal to oscillate. The second coil is set for either twice or three times this frequency. The voltage developed across this second tuned grid is at 2 or 3 times the crystal frequency. The coil in the plate circuit of the harmonic generator tube is normally set for twice the frequency applied to the harmonic generator grid. This is the final or carrier frequency, and the coil in the plate circuit of the modulating amplifier is also set for this frequency. Thus the carrier frequency is normally either four or six times the crystal frequency. With the help of the

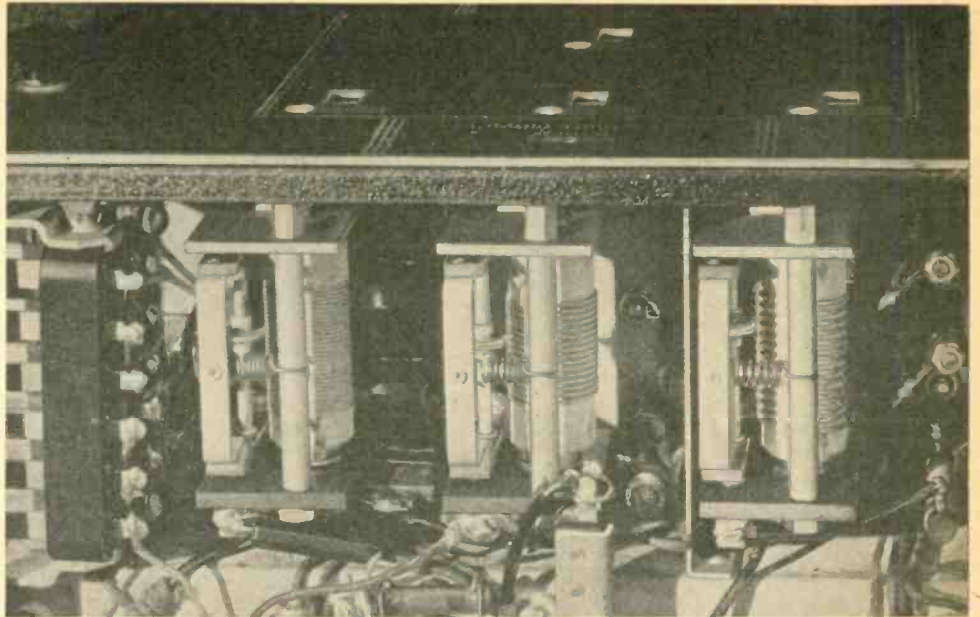

FIG. 4—View of under side of the 18A Transmitter showing three of the continuously adjustable coils

charts, the set can be approximately tuned before power is applied to the transmitter. A slight readjustment for maximum output is then made on the completed installation and no further attention is required.

One of the interesting features of this transmitter is the provision for changing from "talk" to "receive", during a two-way conversation. The same antenna is usually employed for both the transmitter and the receiver and a relay is incorporated in the radio transmitter which switches the antenna back and forth between receiver and transmitter as required. Contacts are provided on this same relay which connect plate power to the transmitter and disconnect plate power from the receiver when the antenna is connected to the transmitter, and reverse this operation when the antenna is connected to the receiver. Two ways of operating this relay are provided, and at the time of installation the user may select the type he prefers. One method utilizes a "press-to-talk" switch in the handle of the telephone handset. When this switch is pressed the transmitter is operating, and when it is released the receiver is operating. The alternative method utilizes a voice-operated relay, furnished as a part of the transmitter, which

closes the circuit to the main change-over relay. Audio-frequency currents generated by the speaker's voice are amplified and rectified so they may actuate this voice-operated relay. With this method of operation the radio system is changed from "receive" to "transmit" as soon as someone talks into the handset microphone. Consequently, this arrangement gives a very fast and simple operating procedure.

A toggle switch, mounted on the control unit that carries the handset, is used to apply power to the transmitter to make it ready for operation. The operation of this switch energizes the filament circuits and starts the dynamotor, so that the transmitter is ready for instant action. Normally the receiver is connected to the antenna, but as soon as the patrolman speaks into the handset microphone, the antenna is switched over to the transmitter, and plate power is applied. These relays are very fast operating so that usually only a small portion of the first syllable is lost. The antenna relay is of the slow release type and thus does not drop out between words, but as soon as the speaker pauses at the end of a phrase or sentence, the relays release and put the system in the "receive" position.

10-Meter Reports from W6AVT and W6IDF

● A. V. and R. J. Tronske, 1001 Dexter street, Los Angeles, California, report unusual activity on the 10-meter band between the dates of August 11 and October 3, 1935. Readers of "RADIO" are invited to write these amateurs for further details on 10-meter schedules, etc. W6AVT and W6IDF are old-timers in the game, having started in 1911. Their transmitter uses only 40 watts input on 10 meters. 24-hour listening periods are a common occurrence and the reports here printed should be of interest to all 10-meter operators. W6AVT and W6IDF have been on the 10-meter band consistently for more than four years. During the months of September, October, November and December, the best months for 10-meter operation, according to W6AVT-W6IDF, a 24-hour vigil has been maintained on this band. Some interesting comment is found in the station log. W6AVT-W6IDF have offered to give us this information for publication, if readers express a desire to see it in print.

Here are a few excerpts from the log:

Aug. 11, 1935—W6DRZ—1:30 PM—Fone R-9
 Aug. 11, 1935—W6KUZ—2:30 PM—CW R-9
 Aug. 14, 1935—W7DSC—6:20 PM—CW R-6
 Aug. 14, 1935—W6JJU—6:30 PM—CW R-9
 Aug. 17, 1935—W6QF—8:40 PM—CD R-6
 Aug. 25, 1935—W6JJU—11:27 AM—CW R-9
 Aug. 25, 1935—W6UP—11:30AM—CW R-7
 Aug. 25, 1935—W6DQT—11:50 AM—Fone R-9
 Aug. 26, 1935—W6BXV—8:00 PM—CW R-8
 Aug. 28, 1935—W6CXW—8:01 PM—CW R-8
 Aug. 29, 1935—W6DIO—7:40 PM—CD R-8
 Aug. 29, 1935—W6DH2—7:45 PM—Fone R-9
 Aug. 29, 1935—W6JEX—7:50 PM—Fone R-7
 Aug. 30, 1935—LU-1EP—12:35 PM—CW R-7
 Sept. 1, 1935—W6JJU—9:05 AM—CW R-9
 Sept. 1, 1935—LU-1EP—10:00 AM—CW R-8
 Sept. 1, 1935—W6DH2—10:30 AM—CW R-9
 Sept. 1, 1935—W7AVV—11:10 AM—CW R-9
 Sept. 1, 1935—W6LTR—2:15 PM—CW R-8
 Sept. 8, 1935—W6BXV—11:10 AM—CW R-8
 Sept. 10, 1935—W6JDH—7:30 PM—Fone R-9
 Sept. 19, 1935—X1AY—4:30 PM—CW R-9
 Sept. 19, 1935—W6DQT—7:45 PM—CW & Fone R-9
 Sept. 29, 1935—W6JJU—11:40 AM—CW R-9
 Sept. 21, 1935—W4AJY—2:30 PM—CW R-9
 Sept. 21, 1935—W6DQT—2:55 PM—MCW R-9
 Sept. 22, 1935—W6JJU—11:25 PM—CW R-9
 Sept. 23, 1935—X1AY—4:10 PM—CW R-8
 Sept. 23, 1935—W6JDH—4:50 PM—Fone R-9
 Sept. 25, 1935—V-AY—3:00 PM—CW R-9
 Sept. 25, 1935—W6JJU—3:20 PM—CW R-9
 Sept. 25, 1935—W2GJB—2:50 PM—CW R-6
 Sept. 28, 1935—W2GJB—12:15 PM—CW R-6
 Sept. 28, 1935—W4AGP—12:20 PM—CW R-5
 Sept. 28, 1935—W6KBB—12:40 PM—CW R-9

Sept. 28, 1935—X1AY—2:50 PM—CW R-9
 Sept. 28, 1935—W6VQ—2:55 PM—CW R-9
 Sept. 28, 1935—VE3JS—3:30 PM—CW R-5-7
 Sept. 28, 1935—W6DHZ—4:10 PM—Fone R-9
 Sept. 28, 1935—VK2LZ—4:30 PM—CW R-7
 Sept. 28, 1935—W6DIO—4:40 PM—CW R-6
 Sept. 28, 1935—W6DHZ—7:00 PM—CW R-8
 Sept. 28, 1935—W2GJB—10:50 AM—CW R-8
 Sept. 29, 1935—W7AVV—10:55 AM—CW R-8
 Sept. 29, 1935—W6GRX—10:58 AM—CW R-8
 Sept. 29, 1935—W6UP—11:00 AM—CW R-8
 Sept. 29, 1935—W6JJU—11:02 AM—CW R-8
 Sept. 29, 1935—W7EPB—11:05 AM—CW R-8
 Sept. 29, 1935—W6KBB—2 PM—CW R-8
 Oct. 1, 1935—W4AJY—2:11 PM—CW R-99
 Aug. 1, 1935—W6DMP—2:30 PM—Fone R-9
 Oct. 1, 1935—X1AY—3:25 PM—CW R-9
 Oct. 1, 1935—VK2LZ—3:28 PM—CW R-7-8
 Oct. 1, 1935—W81XS—3:30 PM—CW R-9
 Oct. 2, 1935—W2FDL—12:30 PM—CW R-8
 Oct. 3, 1935—W9KPD—1:20 PM—MCW R-8
 Oct. 3, 1935—ON4FE—1:21 PM—CW R-7
 Oct. 3, 1935—W6DIO—1:23 PM—CW R-7
 Oct. 3, 1935—W4AJY—1:24 PM—CW R-99
 Oct. 3, 1935—X1AY—1:30 PM—CW R-9
 Oct. 3, 1935—HC2CV—1:32 PM—CW R-5
 Oct. 3, 1935—W8CXF—1:35 PM—CW R-6
 Oct. 3, 1935—W8AGO—1:40 PM—Fone R-9
 Oct. 3, 1935—W9KPD—1:40 PM—CW R-7
 Oct. 3, 1935—W4HC—4:02 PM—CW R-5
 Oct. 3, 1935—W4AJY—2:22 PM—CW R-99
 Oct. 3, 1935—W6JJU—2:25 PM—CW R-8
 Oct. 3, 1935—VK2LZ—2:45 PM—CW R-6-7
 Oct. 3, 1935—W4MR—3:40 PM—CW R-8
 Oct. 3, 1935—W8ITK—3:45 PM—CW R-7

1/4-KW Variactor Controlled Carrier Phone

By FRANK C. JONES

● This transmitter uses the variactor system for controlled carrier phone operation. A linear RF stage is used to efficiently amplify the controlled carrier output of the Class C stage output. The efficiency of a linear stage under these conditions is much higher than for a normal straight linear stage, consequently an effective carrier of about 250 watts can be obtained with fairly-good voice quality. The output is roughly twice as high as can be obtained with the same tubes in an uncontrolled carrier transmitter at the same plate voltage.

The carrier is varied in accordance with the voice modulation. A Class B audio modulator has a large swing of plate current, and this varies the saturation in an iron core of a variactor. The AC windings on this iron core vary in reactance in accordance with the DC saturation and therefore this reactance is used to control the AC line voltage supply to the Class C modulated stage. For amateur purposes, the distortion effects can be kept low enough to permit good voice transmission.

The advantages are in reduced interference due to a reduction in the steady carrier, longer tube life, greater output for a given cost, and high-level modulation, even at low voice levels, resulting in better DX.

A cathode ray oscillograph was used to study the characteristics of this transmitter. The figures obtained on the oscilloscope tube were traced and they are here reproduced. A steady tone input from a 400-cycle sine wave oscillator was used into the speech amplifier through an attenuator. The RF exploring coil was connected to the vertical plates of the oscilloscope and a trapezoidal figure was used in most of the tests. One "sine wave" figure, No. 7, was used as a comparison to the same operating conditions as used for the trapezoidal figure of No. 5.

Fig. No. 1 shows the output obtained from the modulated Class C stage using a type 10 tube with the controlled carrier shut off by means of a front panel switch. This is a

good triangle, showing good modulation characteristics of this Class C stage, and also including all of the audio system.

Fig. 2 shows the same Class C stage with the controlled carrier in use. There is a tendency for overmodulation at all levels, probably due to time lag in the iron-core variactor, power transformer and rectifier filter system. This figure was typical of the operation of this stage, being neither as bad nor as good as could be obtained under usual operating conditions.

The remaining figures were taken with the output of the Class B linear RF stage coupled to the oscilloscope and to a dummy antenna. Fig. 3 shows what happens when the final amplifier is allowed to run with too much RF excitation from the Class C stage, and with over-modulation thrown in for good measure. Many controlled carrier phone stations now on the air are apparently operated in this condition.

Fig. 4 shows the results obtained when the final plate current was not over 200 MA and the grid current not over 2 MA in the modulated controlled carrier condition. The equivalent carrier, with an 1800-volt plate supply on the two 211D tubes, was only about 150 watts, as near as it was possible to measure it and calculate its actual value. This is not appreciably greater than could be obtained without controlled carrier, although the tubes operated cooler.

Figs. 5 and 6 show conditions of higher input to the modulated stage and to the linear stage. In Fig. 6, the antenna load was a little greater than for Fig. 5, although in both cases it was very heavily loaded in comparison to a plate modulated final stage. The distortion is very noticeable on the oscilloscope, but it sounds pretty fair on the air when using voice with plate current kicks up to 300 MA. In these figures the grid current ran about 4 or 5 MA into the final stage, and 10 MA into the 10 stage. The Class C 10 plate current was about 50 MA with the steady tone, the buffer about 20, the 53 cathode current about 50 MA, and the linear stage bias set as 135 volts.

Best quality was obtained when 135 volts of C bias was used on the final stage because this was near cut-off under conditions of full load and power output. A swinging choke input was used in the high voltage power supply, but there was about 150 volts change, 1750 to 1900 when the final plate current changed from 300 MA to 30 MA. Best results were obtained with the bias at 135, even though the final plate current would not go below 50 MA without any RF or audio excitation on the grids. Better plate supply regulation on this stage would allow higher bias, real cut-off value, and prevent distortion entering at this point. A variactor for this stage, adjusted for operating conditions, would be desired for maintaining the plate supply at exactly 1800 under all conditions. The 211D tubes used were of a type with good spacing between leads in the glass stem in order to stand this high plate voltage.*

A diaphragm type crystal microphone was used for voice operation, enough audio amplification being available for speaking about 8 or 10 inches away from the microphone. The quality was best, in monitor tests, when the gain control was turned down with close talking to the mike because the room reverberation and breathing noises were objectionable. A 2A6, with the diode elements connected to cathode, was used as a high-gain resistance coupled speech amplifier. It was necessary to shield the tube,

* Amperex.

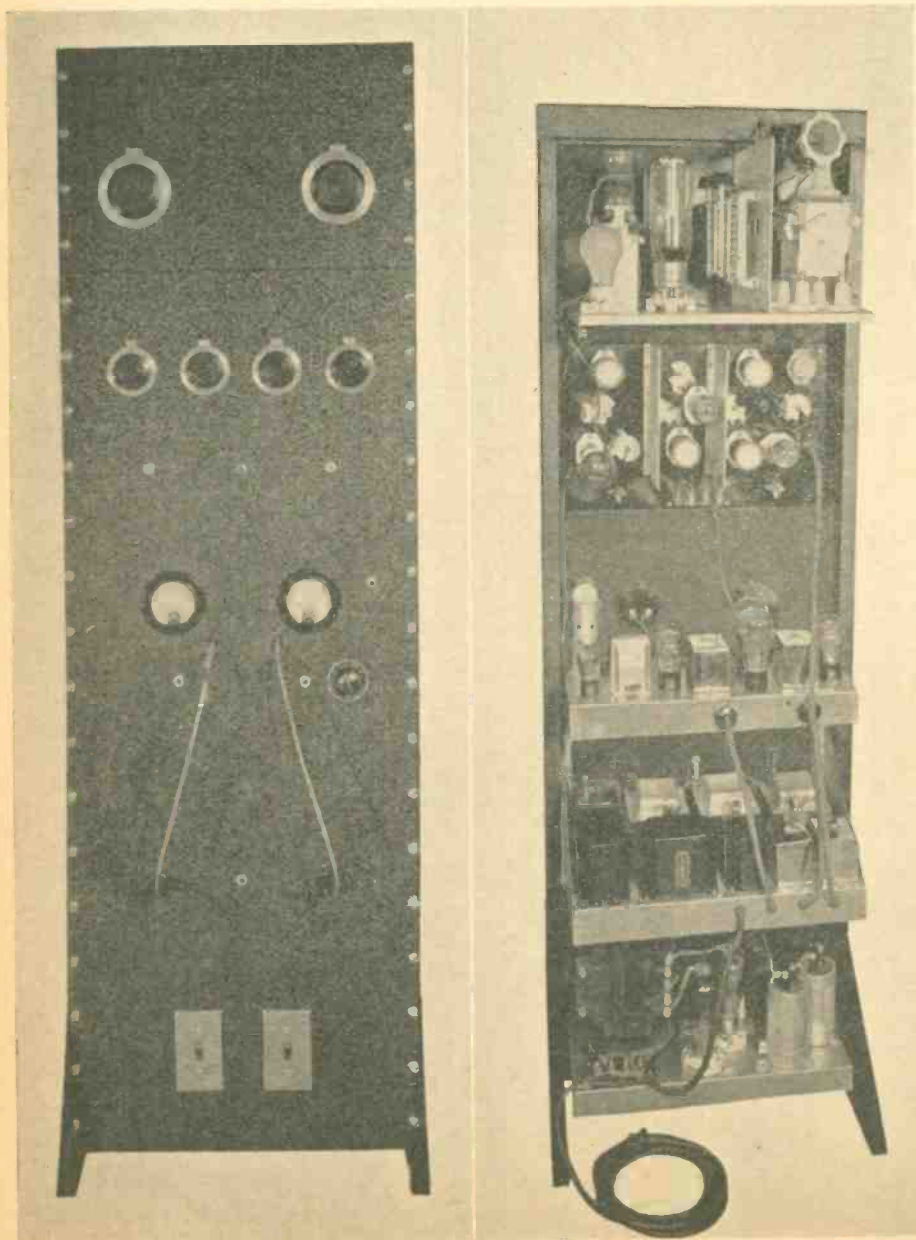

Front and Rear Views of the 1/4-KW Variactor Controlled Carrier Phone.

grid lead, grid leak and jack, as well as the mike plug, in order to prevent stray AC hum pick-up. The 2A6 drives a 56 transformer coupled, 1-to-3 step-up ratio, to a 2A5 triode driver stage. The latter drives a pair of 46 tubes in a conventional Class B audio amplifier or modulator. The "5000" ohm winding of this Class B audio amplifier worked into an average 7500 ohm load presented by the Class C stage. For ideal conditions, the plate current of the Class C stage should vary in exact ratio with the plate voltage on this controlled stage. The plate voltage is varied in accordance with the Class B modulator DC current supply.

A 45 tube operating from a separate filament supply winding was used as an over-modulation indicator; that is, it was hopefully wired into the circuit for that purpose. When a low reading milliammeter is plugged into this 45 tube circuit jack, over-modulation will produce current kicks whenever the AC peak voltage out of the Class B system exceeded the DC plate supply to the 10 stage in value. In other words, the negative AC peaks, when greater than the positive DC voltage, would cause the 45 tube to act as a diode with a current indication in the milliammeter. Very little use has been made of this circuit to date, but it should be incorporated in the set in order to fulfil the RFC regulations.

Relay rack and panel construction is used with five panels about 19-in. x 12-in. in size of No. 14 gauge iron. The high voltage power supply is built so that all of the transformers and chokes are mounted on the front panel, with only the 866 rectifier tubes, 2 mfd. 2000 volt condensers, bleeder and terminal strip mounted on the chassis. The chassis is 17-in. x 9-in. x 1 1/2-in., of No. 20 gauge lead plated steel.

The low voltage power supply panel uses a chassis 17-in. x 11-in. x 2-in. with the three power transformers, variator and auto-transformer AV-1 and chokes mounted on it. The filter condensers and bleeders are mounted underneath this chassis. An 82 rectifier is used on one of the power supplies in order to use a 2 1/2-volt winding for its filament supply. The filament windings on the transformer used to supply the Class C modulated stage cannot be used because the primary voltage varies over wide limits in accordance with syllabic modulation. Since the power requirements on all of this equipment are moderate, the transformers and chokes are neither large nor expensive.

The modulator deck uses a chassis 17-in. x 8-in. x 2-in. The two meters, a 0-50 and a 0-500 or 0-300 milliammeters are also mounted in this panel. The current measuring jacks are arranged in the circuits in such a manner that they will break the center-tap leads in order to eliminate sparking or flash-over. Many of these jacks had to be mounted in insulating washers because in some circuits the sleeve of the jack is not grounded. A telephone plug and flexible cord allows either meter to be used in any circuit jack.

The low power RF deck is made with a vertical bakelite subdeck, 16-in. x 8-in. x 1 1/8-in., mounted on 1 1/4-in. studs from the front panel. This 1 1/4-in. space allows room for wiring, resistors, condensers and insulated flexible shaft couplings for the variable condensers. Two 8-in. x 6-in. aluminum shields are placed around the buffer 45 stage to prevent reaction between RF stages.

The top deck is made with a chassis 17-in. x 11-in. x 1/2-in. of 12 ga. aluminum, with a vertical partition between the plate tank circuit and the remainder of the final amplifier parts. This vertical partition strengthens the chassis, fastens to the front panel, and provides a mounting surface for the two neutralizing condensers on stand-off insulators. All of the parts are arranged symmetrically so

that all leads in each side of this push-pull stage are equal in length, in view of the fact that a split plate coil was to be used instead of a split-stator condenser. The care taken here was well justified. Tests with an oscilloscope showed that excellent neutralization could be obtained.

On 75 meters, the tank condenser should have a used capacity of between 50 and 100 mmfd. with the heavy degree of antenna loading necessary for linear amplification. A split-stator condenser with 200 mmfd. each

would be provided by the grid circuit of the linear stage. About half or more of the Class C stage output is used up in this resistor. Since it is in series with the link coupling, more turns are needed, 5 turns being used around the center of the 75 meter plate coil and 2 turns around the center of the 211 grid coil. Ordinary 20 ga. hook-up wire is used for the loops and links. When the set is used for CW, a 5000 ohm 50 watt grid leak should be plugged into the final grid current measuring jack, or in



Oscilloscope Pictures of the Controlled Carrier Transmitter here described.

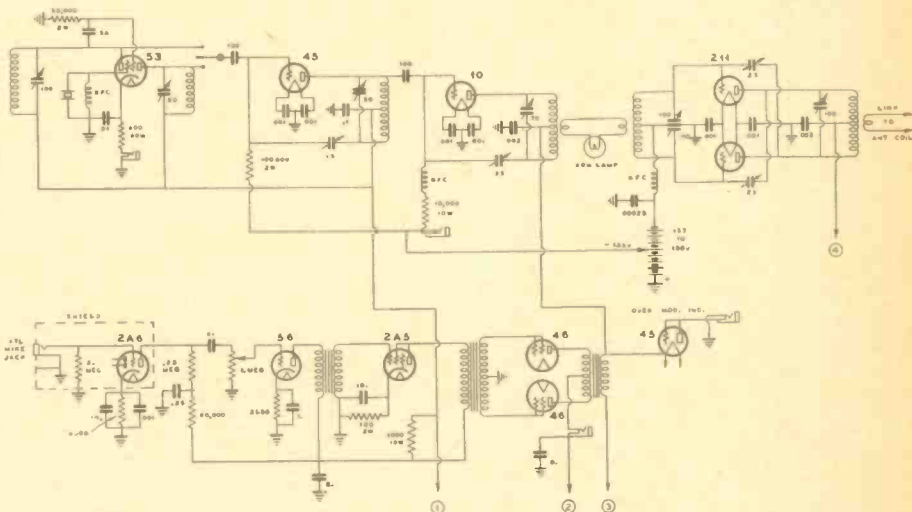

Complete circuit diagram of the r-f, speech, Variator control and power units for the 1/4 KW phone transmitter. Although the circuit diagram shows type 211 tubes in the final r-f amplifier, the tubes actually used in this transmitter were Amperex type 211D. Standard 211 types can also be used without change in the circuit. This transmitter has been given a thorough try-out on the air, and reports from amateurs 1000 miles away state that the voice quality is good, the signal strength R9 plus. As can be seen from the circuit, the Jones Exciter is used to drive the 45 stage which, in turn, is capacitively coupled to the single 210 driver for the 211s in the final amplifier.

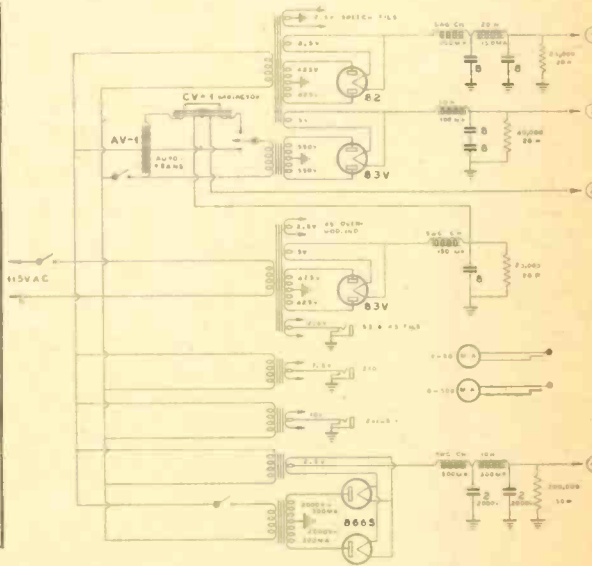

side of center and with sufficient plate spacing, would be as large as the entire amplifier assembly, so the equivalent 100 mmfd. 7000 volt single-section condenser was used. The coil is center-tapped and by-passed to ground with a 5000 volt .002 mfd. mica condenser. No plate RF choke is needed. The use of split plate coils, rather than split-stator condensers throughout, requires less grid driving power in each stage. Capacity coupling between the low power stages can therefore be used, with a resultant saving of space.

A 25 or 40 watt Mazda lamp is used as a plate load for the Class C stage. This resistor provides a more constant load than

series with the C battery lead. The link coupling should then have about one turn at each end, without the series lamp. Keying can be done in the 53 cathode current jack because fixed-plus-grid-leak-bias is used on all stages. External B batteries are normally used for C batteries; the total charging current is low, between 10 and 15 MA for phone operation.

Link coupling of 2 or 3 turns is used between the final tank coil and an external tuned antenna coil circuit. This plate coil for 75 meters is made of No. 12 wire on a 2 3/4-in. form, seven turns per inch, with a total of 22 turns, center-tapped. All coils,

(Continued on page 33)

★ Special Feature

Regenerative R. F. at 5 Meters

By FRANK C. JONES

• The conventional RF amplifier is generally used on 5 meters in order to prevent receiver radiation. The increase in sensitivity is very slight. However, the improved circuit shown in the accompanying diagram gives a very decided increase in sensitivity due to the use of a type 954 Acorn Pentode with controlled regeneration. Using the tube as a straight RF amplifier, a modulated test signal was just barely audible through the noise in a loud-speaker because the signal was very weak. But when the cathode tap was moved up to a point where regeneration was secured, and with the screen voltage adjusted to a point just below regeneration, the test signal was brought up to good loud-speaker volume.

The input impedance of an ordinary screen grid tube is quite low at 5 meters, being only a few thousand ohms. Because this resistance is across the tuned grid circuit, it prevents any appreciable gain or selectivity from being obtained in the tuned input circuit. An Acorn tube has a much higher input resistance than a 6D6 or 6C6 tube at high frequencies, with the result that greater gain and selectivity can be obtained. Regeneration greatly improves both of these factors and its use is well worth while if the inconvenience of one additional tuning control can be tolerated.

The 954 tube is also capable of giving good amplification on the 2½-meter band. For this reason the super-regenerative detector is mounted close to its tuned circuit in order to obtain super-regeneration on 2½ meters as well as on 5 meters.

Super-regeneration is used in this receiver because of its simplicity and ease of satisfactory operation.

Type 37 and 76 tubes both were used, the 76 super-regenerating with a lower plate voltage than the 37. Transformer coupling to a 41 pentode audio stage provides ample output for operation of a 5-inch dynamic loud-speaker.

Tests were made with and without a separate interruption frequency tube, which can be either a 76 or 37. Various values of grid leaks to ground and to plus B were tried, and the combination shown in the diagram seemed to be most practical. It was found that a positive potential connection to the grid leak gave better audio quality, good sensitivity and greater audio output than any of the usual systems which use a separate IF tube. Several values of grid tuning condenser on the IF coil unit were tried. In the circuit shown, no condenser is required. The final result was a super-regenerative detector which gave good quality output without the high level of hiss when no carrier signals were tuned in on the receiver. The separate IF tube allows a drop in hiss without much difference in sensitivity. The noise level is not as great as in most super-regenerative receivers when receiving weak signals, and it is much lower in volume in the loudspeaker than the voice level, when a station is tuned in or out.

The receiver is built on a plated steel chassis, 12-in. x 6-in. x 2-in., with a 5-in. x 5-in. shield between the RF stage and detector. The acorn tube is mounted so that it protrudes through a half-inch hole in the shield, with the plate lead connected to the coupling condenser. This condenser can be set to a value as high as 30 mmfd. for 5-meter operation, and it couples the RF stage

to the detector tuned circuit. Two dial control is used for tuning because RF regeneration is used, necessitating exact tuning of the RF stage. The detector tuning condenser shaft must be insulated from the chassis and front panel. Plug-in coils are used to cover any band from 2½ to 10 meters.

The receiver chassis is mounted on a large front panel, 13¾-in. x 18-in., of No. 12 gauge aluminum. Below this chassis is mounted another chassis with power supply for operation on 110 volts AC. On this same power supply chassis is a pair of 42 pentodes in parallel, driven by a 76 tube, for use with a single-button microphone. The screen voltage on the pentodes is about 250 volts, and the plate voltage is about 350 volts, resulting in 10 watts of audio output for purposes of modulating an external parallel rod oscil-

lator. When receiving, the loudspeaker field coil drops the 350 volt plate supply to 250 volts for the receiver tubes. These features need not be included for the receiver here described, but they have been used at W6AJF for several months in experimenting with various forms of parallel rod 2½ and 5 meter oscillators.

The plug-in coils are wound of No. 14 or No. 12 tinned wire so as to fit into ordinary telephone tip jacks. Three jacks for each coil are necessary; they are mounted near the tuning condenser terminals in order to provide short leads. An old hard rubber panel was used for the 2-in. x 4-in. coil and condenser supports. Hard rubber has less RF loss than most bakelite material and the tip jacks can be mounted on these panels without appreciable signal loss. The RF chokes are made by winding about 75 turns of No. 24 DSC wire on a ⅜-in. rod, slipping it off the rod, and mounting between its ends as

(Continued on page 32)

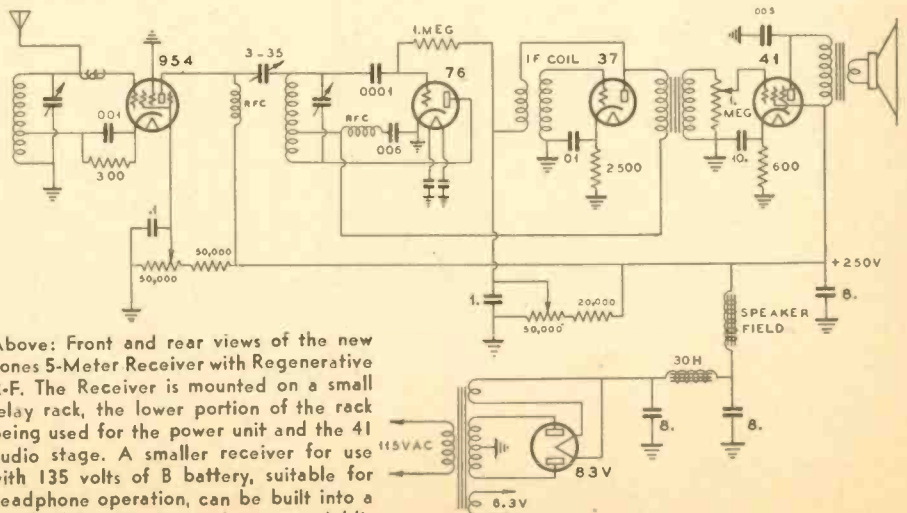
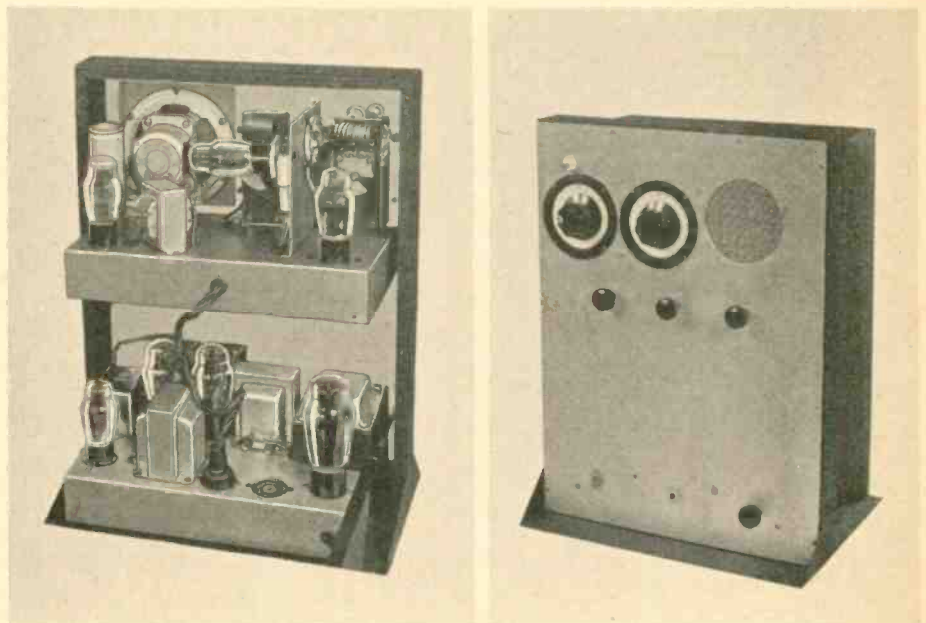

Above: Front and rear views of the new Jones 5-Meter Receiver with Regenerative R-F. The Receiver is mounted on a small relay rack, the lower portion of the rack being used for the power unit and the 41 audio stage. A smaller receiver for use with 135 volts of B battery, suitable for headphone operation, can be built into a standard 5-meter transceiver case. Additional details on this new Receiver will be in December "RADIO."

The Design, Measurement and Operation of R. F. Chokes

By W. H. FORTINGTON*

● Perhaps the most overlooked item of the amateur radio transmitter is the RF choke coil. In fact the number of magazine articles appearing on the subject have been so few as to pass almost unnoticed. Practically all such articles, few as they have been, have overlooked the most important point of interest to the amateur, namely, a choke which will cover a number of frequency bands, such as used by the amateur.

The chief requirements with which a good RF choke must meet are the following:

(1) The reactance of the choke coil must be high compared with the impedance of the tube on all bands in which the circuit is to be used.

(2) The distributed capacity of the choke coil must be as low as practicably possible, and at the frequency at which the coil is operated the impedance must not be entirely limited by this factor.

(3) The LC combination of the coil must not produce resonance with the frequency under consideration, otherwise circulating current is likely to flow in the circuit with disastrous results to the coil.

Before entering into any detailed considerations of the design of RF chokes there is one point often misconstrued which might well be cleared up before proceeding, namely, that at frequencies above the resonant frequency of the coil the choke becomes entirely capacitive. This is not by any means true for if this consideration was reasonably sound the reactance of the choke would gradually decrease at frequencies above resonance more or less inversely as the frequency. By referring to Fig. 1 it will be seen that this is not the case.

From Fig. 1 it will be seen that a choke coil having a resonant frequency about 1500 KC has a number of "repeat" points of maximum impedance at frequencies somewhere near the harmonic frequency of the coil. This repeat point is governed by a number of factors, the chief of which perhaps is the effect of the distributed capacity of the coil itself; after a measurement of the distributed capacity of a coil, the reason for this becomes more apparent.

In the design of a choke coil it must be borne in mind that the self capacity of the coil is distributed over the entire coil in sections and is not a lumped capacity of the type used in a tuned circuit. At resonance,

total capacity of the circuit then an entirely different condition is apt to be encountered. The initial investigation of the function of choke coils immediately indicates that the distributed capacity of the coil must be kept to an absolute minimum if the choke is to operate as such, over a band of frequencies of from say 1700 KC to 30,000 KC. After all, the efficiency of the choke in circuit is governed by the relative impedance it presents at its operating frequency with respect to the impedance of the circuit (usually the plate or grid circuit of a tube.) While attempts have been made to design a choke so that a maximum impedance will be obtained in each amateur band, this condition can seldom be met in practice because there is little knowing what type of circuit the choke is going to be used in, or how it will be operated, such factors having a large bearing on the efficiency of the choke. Referring to Fig. 1 it will be seen that the peaks of maximum impedance fall approximately in each amateur band. As previously stated, this condition is subject to modification through the effect of the circuits used in conjunction with the choke.

It will be noted that the "peaks" of impedance become smaller as the frequency increases and the valleys commence to fill in and at the higher frequencies the impedance presented is quite uniform over a wide band since the function of the choke is then entirely capacitive.

In general it may be said that the reactance of the coil is capacitive at frequencies above resonance except near the "harmonic frequencies" of the coil which usually lie in the vicinity of the points of maximum impedance.

Measurement of Distributed Capacity

Some of the early work performed in the measurement of distributed capacity of coils was based on formulas and systems made public by the Bureau of Standards in Circular No. 74, entitled "Radio Instruments and Measurements" and while in themselves the systems enumerated were reasonably accurate, the apparatus with which the work at that time was done was by no means conducive to satisfactory results. The distributed capacity

of a coil is indicated by $C = \frac{Cf \cdot 4C2f}{3}$, where

(Continued on page 28)

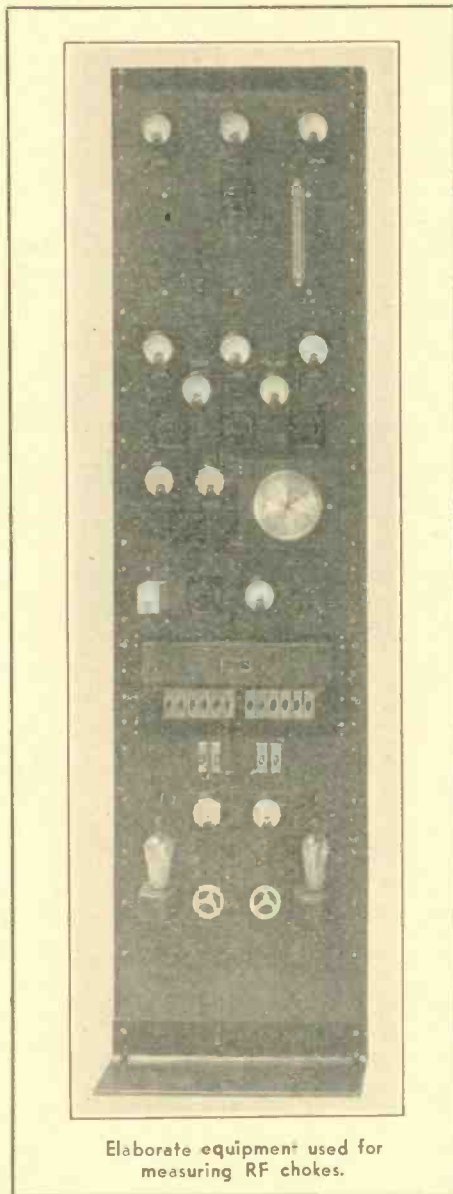

Elaborate equipment used for measuring RF chokes.

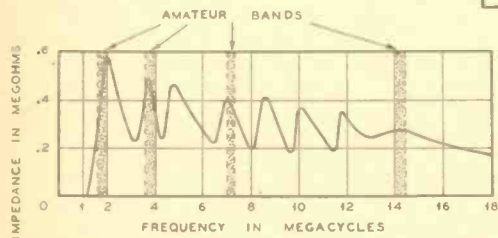
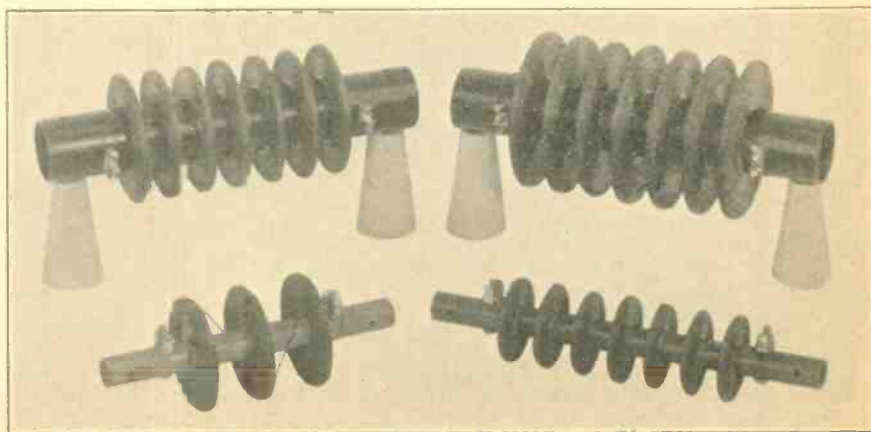

FIG. 1

Repeat points of maximum impedance at frequencies somewhere near the harmonic frequency of the coil.

therefore, the circulating current flowing through the extraneous capacity will not assume the same proportions as if it were a circuit deliberately tuned. This holds good nearer to the resonant frequency of the coil, but should the distributed capacity of the coil form a relatively large portion of the

* President, Amateur Service Sales, Chicago, Ill.



A group of navy type chokes for broadcast and amateur bands. Left hand front is short wave choke covering band of 180 meters to 20 meters. Note the relatively wide spacing between coils and the way the leads are brought off between sections.

A Battery Operated Phone

2 1/2 Watts Carrier . . . 135 Volts Plate Supply . . . Dry Cell Tubes

● Many amateurs reside in localities where no electric power is available. The numerous requests for information on the construction of a low power battery operated phone or CW set for use on 160 or 80 meters has prompted the writing of this article. A battery-operated transmitter is also ideal for use by expeditionary forces, for campers, etc. The transmitter here shown is built on a breadboard, but a small shielded unit could be built for portable use, if desired.

The carrier output is about 2 1/2 watts with 135 volts plate supply and 4 1/2 volts at 1/2 ampere filament supply. Only two tubes are used for CW, thereby reducing the battery drain. Lower power sets than this one have operated over distances of several hundred miles at night, when there was no QRM.

The circuit consists of four type 19 tubes with the filaments in series-parallel. The 19 tube is about the most powerful dry cell type tube available and it can be used as a crystal oscillator, RF amplifier, speech amplifier and Class B modulator. It also makes a good regenerative detector and single stage audio amplifier. Connecting the filaments in series-parallel eliminates the need of a filament rheostat and also provides sufficient microphone voltage for most single-button mikes. The two audio tubes are in series, as are the two RF tubes; thus the audio tubes can be cut-off when using CW. Being a filament type tube, the A battery switch also becomes a send-receive switch.

The audio system is a straightforward circuit using a single-button mike, a microphone-to-grid transformer, 19 tube speech amplifier-driver stage, and Class B modulator. The grids and plates of the first 19 tube are connected in parallel and grid bias is furnished by the 2 volt drop through the 19 tube modulator filament by reason of the fact that the negative 4 1/2 volt source is grounded in the circuit. The class B input transformer has a step-down ratio suitable for working between a 19 tube driver and a 19 tube Class B stage. The output transformer is made for a 5000 ohm load. The actual load of the Class C stage is about 6000 ohms and this 5000 ohm load match is therefore satisfactory. Class B transformers designed for working into and out of type 59 tubes can be used, although the smaller size shown in the photo are also available.

The crystal oscillator uses a 19 tube in push-pull with sufficient output to drive the second 19 tube for Class C stage modulation. Link coupling preserves the balance of the push-pull stage and provides better impedance match into the grid circuit of the RF amplifier, resulting in higher grid current than could be obtained with other methods. The oscillator grid leaks are not critical in value, 30,000 ohms giving about the same or very slightly more output than that obtained with the 50,000 ohm 1 watt resistors shown. This is a very effective crystal oscillator circuit for battery operated transmitters.

The modulated RF amplifier stage uses a 19 tube with its grids and plates paralleled, respectively. The simplified low-pass antenna network shown in the diagram calls for the use of grid neutralization. Shunt feed, with a section wound 8 mh. RF choke, is used to prevent +B reaching the antenna lead. The antenna matching circuit here shown is very efficient for matching any length of antenna, and it greatly reduces harmonic radiation.

An overmodulation indicator unit is also

By FRANCIS CHURCHILL

shown because the Federal regulations state that such a device must be used when operating phone transmitters. It consists of a type 30 tube with grid and plate connected together for diode operation without B voltage. A single new dry cell will heat a good 30 tube filament sufficiently for operation as a diode. Old tubes or old batteries require the use of two dry-cells in series, with a variable filament rheostat connected

so as to obtain a deflection on the over-modulation indicator.

This same unit is very useful for checking the output of the crystal oscillator, also for tuning up the entire transmitter. A DC milliammeter, 0-50 range, with plug, should be used for checking plate and grid currents as measured in the jacks shown in the circuit diagram. The crystal oscillator should be tuned by using both the RF indicator and the plate milliammeter, with an open-circuited plug inserted into the RF stage plate jack. As the 100 mmf. crystal oscillator

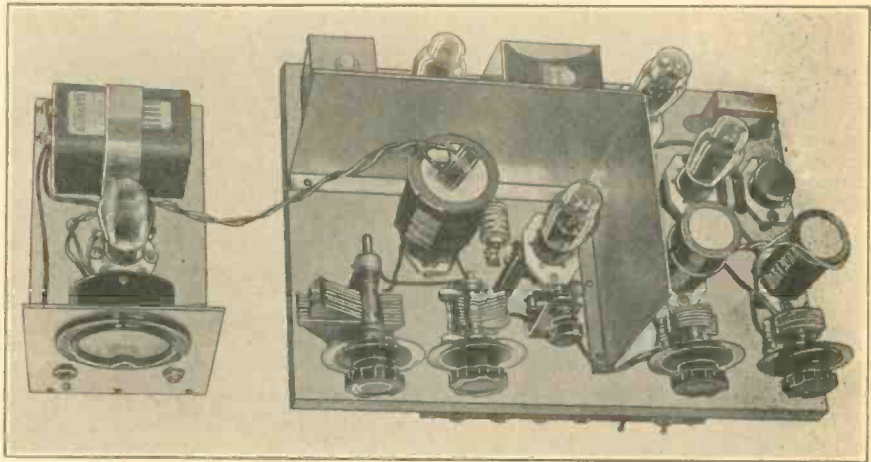

The complete battery operated phone and modulation indicating device.

in series with the "two"-volt filament. A 0-1 MA meter acts as an indicator, and linearity is obtained by means of a 10,000 ohm resistor in series with this meter and pick-up RF coil. This resistor is connected into a closed circuit telephone jack so that a headset can be plugged into the circuit, which is then used as a monitor of modulation quality. Overmodulation is indicated by a flicker of the meter needle during modulation. Talking in a lower voice, or at a greater distance from the microphone, will prevent over-modulation when trouble is experienced from this source. The RF pick-up coil is loosely coupled to the antenna coil

tank condenser is rotated there will be an increase of plate current when the tube oscillates. Oscillation will persist over a range of from about 12 to 30 or 35 MA, with the greatest output toward the 12 MA setting. This is near the high capacity setting at which oscillation will be maintained.

In the transmitter shown, one turn of link coupling proved to be too much, when wrapped around the center of each coil. One turn of the link had to be raised above the end of the winding, as the picture shows. This coupling can be adjusted so as to give greatest grid current when the grid circuit is tuned to resonance. With no plate voltage applied,

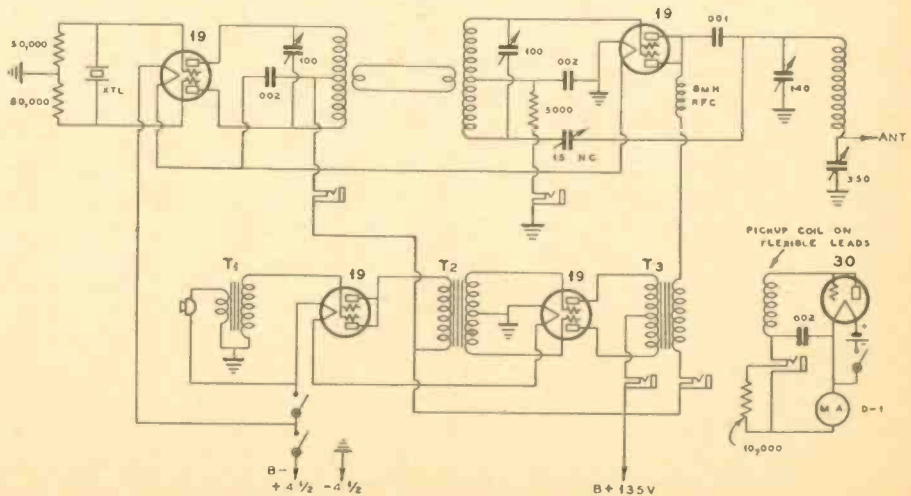

Circuit diagram of the 2 1/2 watt battery operated phone. T1—Mike-to-Grid Transformer. T2—Class B Input Transformer, about 3-to-1 primary to each secondary. T3—Class B Output Transformer for 19 tube to 6000 ohm load.

the grid current should run up to nearly 10 MA. Neutralization is accomplished by using the overmodulation indicator as an RF indicator inside of the plate coil of the RF stage. This stage should be tuned to resonance with the antenna disconnected, and with the open plug remaining in the plate current jack. The neutralizing condenser should be set so that there will be no RF current in the plate coil, and no flicker in the grid current meter when the plate coil is tuned through resonance. The grid current will be greatest at neutralization when the grid circuit is also tuned to resonance.

The antenna circuit is tuned by connecting any fairly long antenna wire and ground or counterpoise to the antenna connection and set ground connection, and by varying the 350 and 140 mmfd. tuning condensers. More coupling to the antenna is required if smaller condenser values are used; the 350 mmf. condenser should be nearly fully enmeshed, as a general rule. The 140 mmfd. condenser is always tuned for minimum plate current; heavier antenna loading increases the minimum reading obtainable. The plate coil may sometimes require fewer or more turns with some antenna systems.

All plate current readings should remain constant with modulation, except the reading

Meters	B. Bat.	I osc.	I grid.	I amp.	Carrier Output	Efficiency Final Amp.
160	138	16	6	25	2.6	74%
80	138	15	5	23	2.4	74%
80	185	20	8	30	4.5	80%

for the Class B audio tubes. The latter should vary from no modulation at about 10 MA, to 20 MA under heavy modulation peaks. A 6-volt flash-light or pilot lamp and a single turn of wire makes a good test indicator for relative modulation percentage. The lamp should brighten up considerably when whistling into the mike when the single turn loop is coupled to the amplifier RF coil. It will be found that less antenna load can be used for phone operation than when using CW. Keying for CW can be accomplished in nearly any of the current measuring jacks of the RF tubes.

Some typical readings for 80 and 160 meter operation are shown in the table above.

The values of output and efficiency are not exact, but they are relatively correct. The 19 tube gives higher efficiency than most other battery operated tubes because of its very high mutual conductance when the two triodes are in parallel.

For 160 meter operation the oscillator and grid coils are wound with 72 turns of No. 22

DSC wire, closewound on a 1½ inch diameter form. The plate coil is wound with 44 turns of No. 18 DSC wire on a 2¼-in. diameter plug-in coil form. The two smaller coils are center-tapped.

For 80 meter operation the two smaller coils are center-tapped, and wound with No. 22 DSC wire on a 1½-in. diameter form, 30 turns about 1½-in. long. The plate coil is wound with No. 16E wire on a 2¼-in. diameter form, with 28 turns about 2½-in. long. The plate coils for either band must sometimes be "pruned" slightly for the correct number of turns for a given antenna.

The 14 gauge aluminum grounded shield, shown in the breadboard transmitter, prevents RF feedback into the grid or oscillator circuit and isolates the modulator apparatus. Some of the small parts are under the breadboard. The dimensions of the oak baseboard are 16-in. x 11-in. x 1-in. Isolantite sockets are used throughout. Good bakelite wafer sockets can also be used, with only a slight sacrifice in efficiency.

Quiet Amplifier Tubes *

By G. L. PEARSON

• A small electrical signal can be amplified by vacuum tubes to any desired amount provided the input voltage to the amplifiers is large enough to override the noises in the input circuit. Some of these disturbances can be eliminated, such as fluctuations of battery voltage, induction, microphonic effects and poor insulation, but others are inherent and it is these latter which determine the limit beyond which amplification cannot be advantageously increased. The fundamental limiting sources of noise are two, namely, thermal agitation of electricity in the external circuits and the voltage fluctuations within the vacuum tubes themselves.

The impedance of the input circuit of high-gain amplifiers is often high or may effectively be made so by the use of a transformer. In this case the contribution of noise from the vacuum tube is small compared with the noise arising from thermal agitation in the input circuit. This is a desirable condition since it furnishes the largest ratio of signal to noise for a given input power. Sometimes, however, the input impedance is perforce so small that the tube noise may be comparable with or greater than thermal agitation noise. Such conditions may arise, for example, in amplifiers where the frequency dealt with is high or the frequency range is wide, in which cases bridged capacities reduce the impedance. It is, therefore, desirable to know the noise level to be expected from different types of tubes that may be used in the first stage of high-gain amplifiers as well as to be able to calculate the thermal noise level of the input circuit.

The noise of thermal agitation, first discovered by J. B. Johnson, arises from the fact that the electric charge in a conductor shares the thermal agitation of the molecules of the substance so that minute variations of potential difference are produced between the terminals of the conductor. The mean square thermal noise voltage at the terminals of an

open circuit resistance R is

$$\bar{V}^2 = 4kTRF$$

where k is Boltzmann's gas constant, T is the temperature in degrees Kelvin, and F is the frequency band width in cycles per second. At

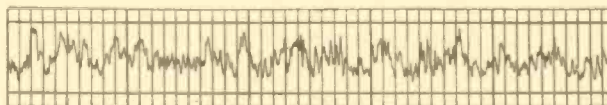

Fig. 1—Noise voltage fluctuations in the plate circuit of a 259B vacuum tube as shown by the rapid record oscillograph.

room temperature $4kT$ has the value 1.6×10^{-20} when V is expressed in volts and R in ohms.

The noise in a thermionic vacuum tube arises from the fact that the space current is not a smooth flow of electricity but is subject to rapid and irregular fluctuations in magnitude. These are made manifest by voltage fluctuations across the external load impedance of the tube. Although the magnitude of this effect is small, it may be heard as a

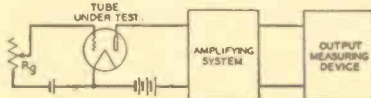

Fig. 2—Schematic amplifier circuit for measuring noise in vacuum tubes.

roar at the output of a high-gain amplifier. Figure 1 shows voltage fluctuations in a Western Electric 259B vacuum tube as recorded by the rapid record oscillograph. While thermal noise in the circuit is accurately predictable, the noise originating in the vacuum tube is not completely understood and cannot be calculated accurately. It is known, however, that the noise arises from a number of different causes. Chief among these are: (1) thermal agitation in the internal plate resistance of the tube, (2) shot ef-

fect from the space current in the presence of space charge, and (3) space charge fluctuations due to positive ions.

Just as voltage fluctuations are produced by thermal agitation in the external circuits, so the internal plate resistance of the vacuum tube is a source of thermal noise. It has been deduced that this resistance pro-

duces thermal noise as if it were at the temperature of the cathode. This is the most fundamental source of noise in vacuum tubes and should set the limit in the ideal low noise tube.

The shot effect arises from the fact that the electrons are emitted from the cathode in a random manner, thus producing statistical fluctuations in the magnitude of the space current. When the cathode is relatively cool so that the emission is limited by temperature, the shot noise is proportional to the average value of the space current, but when the emission is increased so that a space

(Continued on page 29)

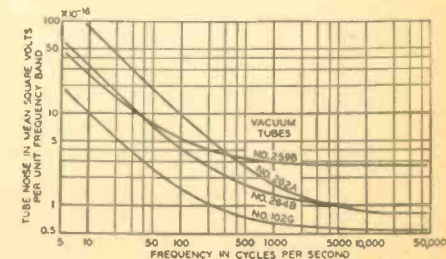

Fig. 3—Noise in standard Western Electric vacuum tubes in terms of the mean square volts per unit frequency band.

*Courtesy Bell Telephone Labs.

● When you ask a fellow about DX at the present time, it seems that he takes it for granted that you want to know about 28 MC. As a matter of fact, there is some swell work being done on ten meters, but at the same time there is still good DX to be had on 20 and 40.

At this writing, there appear two stations who made WACs on 28 MC. W3FAR is the first W, while ZS1H is the first foreign station to make the grade. A lot of the boys have worked 5 continents, and by the time you read this there will probably be many more who have hooked-up with all of them.

On the West Coast, W7AMX has worked ZS1H, making his fifth continent. W6GRX, W6DIO, W6CXW, W6JJU, W5WG, W5BD and W5AFV are very active out here. GRX has just worked D4KPJ and now needs Africa for his WAC. DIO, CXW and JJU have worked 4 continents. W9NY and W5AFX lack Asia for their 6th. W8IXS has heard a mess of good stuff, and has hooked up with D4KPJ and G2HG. Quite a large number of the fellows in the eastern part of U. S. A. are doing themselves proud. W2TP, W2DZA, W3FED, W4AJY, W4MR, W4TZ, W4BBR, W4HC, W4AGP, W4AUU, W8IXS, W8AGU, W8DYK, W9CES, W9HAQ, W9KPD, W9DRN, W9HJA, W9ISU, W9LS, W9GLW are all banging away on ten . . . I don't happen to know what they're working, but they can't keep it a secret forever. VKs and Js with a sprinkling of LUs are in there quite consistently. A few of the favorite European stations include ON4AU, E18B, F8OZ, EA4AO, F8CT, G2YL, D4KPJ, and G6LK. W8GXC says he has heard F8OZ, EA4AO, ON4JB, ZT6K, F8CT, G5SO, G6GS, PA0AZ, G6LK and G2YL. FB, Jimmy! That's about all the dope I can scrape up on the 28 MC band for this time. If all you 10-meter DXers will kick through with some information we'll see if we can devote more space to it next month.

● The old 14 MC band still offers some pretty nice DX. W8CRA has snagged VS6AH, VS6AG, VS6AQ, VS6AX, VS6DB, KA1CM, KA1CS, KA1LB, J8CA, XU6F, XU6F, XU8AL, XU2JM, U9AB, VU2LJ, VS1AJ and CR7GC. Incidentally, CR7GC was Frank's 113th country. Take a look at the picture of XU2JM on this page . . . well, this station is located at Mission Catholique, Yung Ping Fu, (Hopei) China. Most of the operating is done by J. Meijs. The Xmtr uses a Colpitts circuit with 45 watts input. Antenna is a single wire fed Hertz . . . 40 meter. The receiver is a 1-V-1. There are about 27 Dutch Fathers at the Mission and they are very anxious to contact stations in Holland, so you PAO hams better keep an ear open for 'em. Their sig is PDC and comes in around 14,380 KC.

● Some of the fellows have been hearing TC2XX and PF2DB. The question seems to be "Does anyone know their QRAs?" If so, let's have them and we'll make a few hams happy.

● W8CRA has worked 1368 different DX stations, the last one being YM4DSG. The other day he worked VR4BA and the guy was only using .7 watts . . . yes, brother, the VR . . . not CRA. Frank never saw seven-tenths of a watt. I have a feeling that some day he will break down and work some DX for a change.

● Here's something . . . W6DLN in Los Angeles is so busy he only gets on the air about once a week . . . BUT last week when he was spending his night on, here's what he works . . . F7CGV in New Caledonia. That's a nice one to get, especially for a ham out here on the West Coast.

● 7 MC is getting back to normal; in fact, at times it is better than ever before. All continents come through quite regularly and there seems to be a flock of new stations to work. South Africa is doing its stuff and the sigs are rolling in every morning between 1400 and 1600 GMT. Of course, this is on the Pacific Coast. In the evenings they usually pop through again, along with a sprinkling of South Americans. Somewhere between 0500 and 0800 GMT. European stations are being worked by many of the fellows out here. They are making extra effort to contact W6s and

DX



By HERB. BECKER, W6QD

Readers are invited to send monthly contributions for publication in these columns direct to Mr. Becker, 1117 West 45th Street, Los Angeles, California.

W7s, because prior to this year it has not been a very common occurrence for them to hook the West Coast on 40. Most of the boys, both "over there" and on the Coast, use special beam antennas to help in the big push. As soon as the details on these beams can be obtained this column will spring 'em loose . . . and then maybe, I, too, can snag a G, an F, or a OK, or a PA, or a etc., etc. Here's a few W6GRX has heard on 7 MC . . . LY1J, OK1BC, PA0JMW, G5SS, G6WY, G6CJ, G5BD, G6DL, G2PL, OE6DK, OK1HZ, F8EB, F8EX. Not so bad, eh?



Colonel Foster, W6HM, and a mountain lion he bagged on a recent hunting trip.

● For a long time many hams have wondered what the station of F8EO looked like, what his rig had in it, antenna dope, etc. The photo in these columns will give you a fair idea of the

station and the operator, Francois Beviere. F8EO informs me that during this past season he has had over 600 contacts with W6, W7, VE4, VE5, and K6, to say nothing of the rest of the USA, and other countries. Beviere came on the air in 1924 under the call of F8DK and handled much traffic on the 32 meter band. The transmitter, which is used on both the 7 and 14 MC bands, consists of a 59 tritet, 59 doubler, a 210 buffer, the latter being link coupled to the 203A final amplifier. The '03A takes on 1250 volts at 180 MA. Split-stator condensers are used in the last two stages. F8EO can make a few minor changes in this rig, getting it on phone in a hurry. He insists, however, that the phone transmissions are for local communications only, not reliable for good DX. One antenna is used, being a Zepp fed type, a half wave long and the feeders are about 48 feet long. This antenna is directional Northwest and Southeast. For 14 MC the feeders are series tuned, while on 7 MC a Collins network gives excellent results. Francois built his own receiver along the lines of an SW-3 plus a pre-selector stage. He must have done a good job because the old boy sure can hear 'em. F8EO's closest friend is F8EX, and I don't have to tell you that when they are both on the air they certainly grab plenty of QSOs. F8EX, whose name, by the way, is Jean Denimal, has a transmitter quite the same as EOs. Uses a 59 doubler, 210 buffer, and a 203A final. The antenna is a center fed Zepp, and each half of the flat top is 33 feet in length. Feeders are about 66 feet long. Jean's receiver uses this set-up 58-58-2A5, and is extremely sensitive. Oh, yes, I must not forget that he, too, built his own receiver. F8EX doesn't seem to be able to get on the air to do as much brass pounding as he did some time ago, and the only reason I can give is a YL . . . wait . . . no, it's two YLs. From a couple of sources comes word that it is, first, Marinette and then Virginia. Well, anyway, here's wishing him good luck, whether it's a LY venture or brass pounding.

● A card from W6JO says that VR2FF (ex VP1FF) in Suva, Fiji, has been coming in lately on 14,110 KC between 0400 and 0500 GMT. Many of the boys met him personally when he made a trip through USA.

● Remember the famous W6BYB of Sacramento, Calif.? Well, about a year ago the John half of BYB blossoms forth with a wife. I've heard tell that sometimes a thing like that puts the skids on ham radio for a year or so. Guess John figures his "year or so" is about up, and very soon he will be on with a pair of 150Ts in the final.

● W6CXW reports that there are a flock of J8 stations on 40 every morning. J8 is Korea . . . just in case you didn't know. Last year there were a few on the air, but I guess some of the boys over there were just having fun, as none of 'em were licensed. Some hams would call that bootlegging . . . but remember, I didn't say it! Anyway, some of the REAL J8s that are coming through include J8CA, CB, CC, CD and CG. Yep, they send cards now.

● YS1FM bounces through on 7040 KC every now and then. He's in Salvadore, and W6GRL has just worked him for his 88th country. Think CXW hooked him, also.

● ZP2AC in Paraguay has been quite consistent on about 14,350 KC. Fellows all over the country have QSOed him lately.

● It is with profound sorrow that the writer of this column chronicles the passing of amateur radio's great warrior, Colonel Clair Foster, W6HM, of Carmel, California. The Colonel had his first fling at DX many years ago. Later he settled down to a daily routine of amateur message handling between the Occident and the Orient. There's hardly a DXer who hasn't heard the Colonel's signal, at some time. It was his custom to arise at 4 each morning, start the generator which supplied power to his 1 KW transmitter, get going

(Continued on page 24)

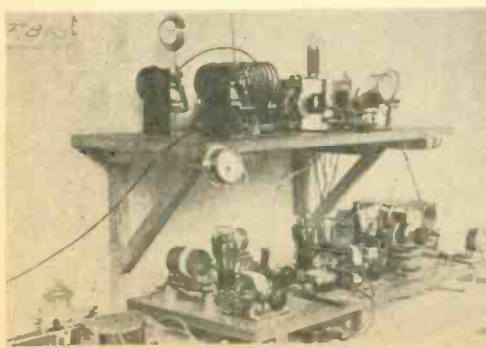

The Rig at F8EO



F8EO

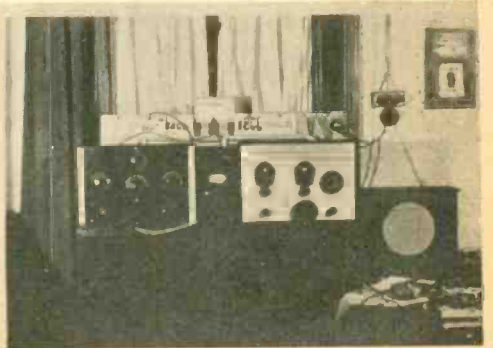

XU2JM

The New RCA AR-60 Receiver—In

● In the design of a high frequency radio receiver there are four qualities of the greatest importance which must be considered. These are usable sensitivity, selectivity, frequency stability and reliability. These qualities have been given careful consideration in the design of the Type AR-60 Receiver as outlined in the following paragraphs.

The sensitivity of this receiver is limited only by the tube noise originating in the first tube and its associated circuits. A large part of this noise is due to "shot" effect and thermal agitation in the first tuned circuit. A signal, to be readable, must produce a voltage on the grid of the same or greater order of magnitude than this inherent noise voltage. Therefore, an efficient coupling system between the antenna and the first tuned circuit of the receiver is of great importance. This has been the subject of considerable development, and the system used on this receiver gives optimum coupling with antenna or transmission line impedances between 50 and 500 ohms over the entire frequency range of the receiver. The question of band changing by means of plug-in coils, separate switch coils or tapped switch coils only after it was proven that the additional tuned circuit loss over that of plug-in coils was negligible in comparison to the resistance load imposed on the first tuned circuit by optimum coupling to a suitable antenna.

The second quality of a receiver, selectivity, is necessarily a compromise with fidelity of the reproduced signal. This receiver is designed to have the maximum selectivity consistent with the fidelity requirements of the various communication services.

To secure good frequency stability, rugged construction of parts and wiring in the high frequency heterodyne oscillator circuit has been included in the design. This, together with voltage stabilization of the oscillator plate supply and proper oscillator excitation provides a high degree of stability.

Equipment

The receiver is supplied in three types, as follows:

- (a) Type AR-60-R (rack-mounted type).
- (b) Type AR-60-T (cabinet type, standard black wrinkle finish).
- (c) Type AR-60-S (cabinet type, special two-tone gray finish).

RCA tubes, one set, including:
 4 RCA-6D6, RF and IF Amplifiers
 2 RCA-6C6, First Detector and First Oscillator

1 RCA-6B7, IF Amplifier, Second Detector and A.V.C.

1 RCA-6F7, CW (beat) Oscillator and Audio Amplifier

1 RCA-41, Output Stage
 1 RCA-84, Power Supply Rectifier
 1 RCA-991, Voltage Regulator.

Circuit Arrangements

General. The circuit is shown schematically in Figure 1. It consists of two stages of RF amplification, first detector, first heterodyne oscillator, three stages of IF amplification, second detector, second heterodyne oscillator, AF amplifier stage, output power stage and power supply system.

Input Coupling. The antenna coupling system is designed to provide optimum coupling from transmission lines (50-500 ohms) or from conventional antenna and ground systems. The coupling is variable and controlled from the front panel. The coupling coils are electrostatically shielded from the



Front View of Type AR-60-S Receiver

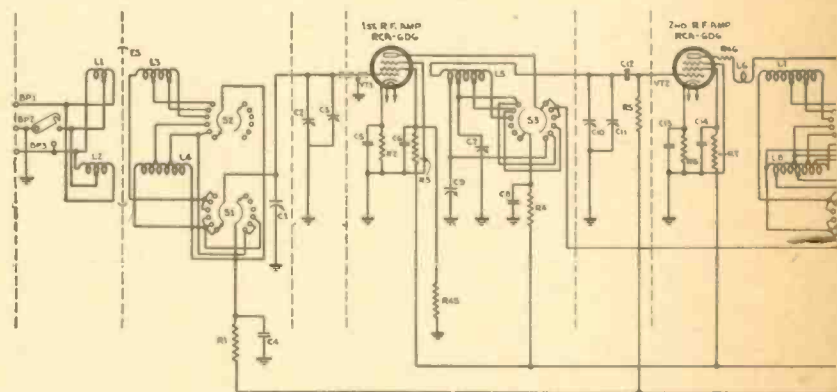
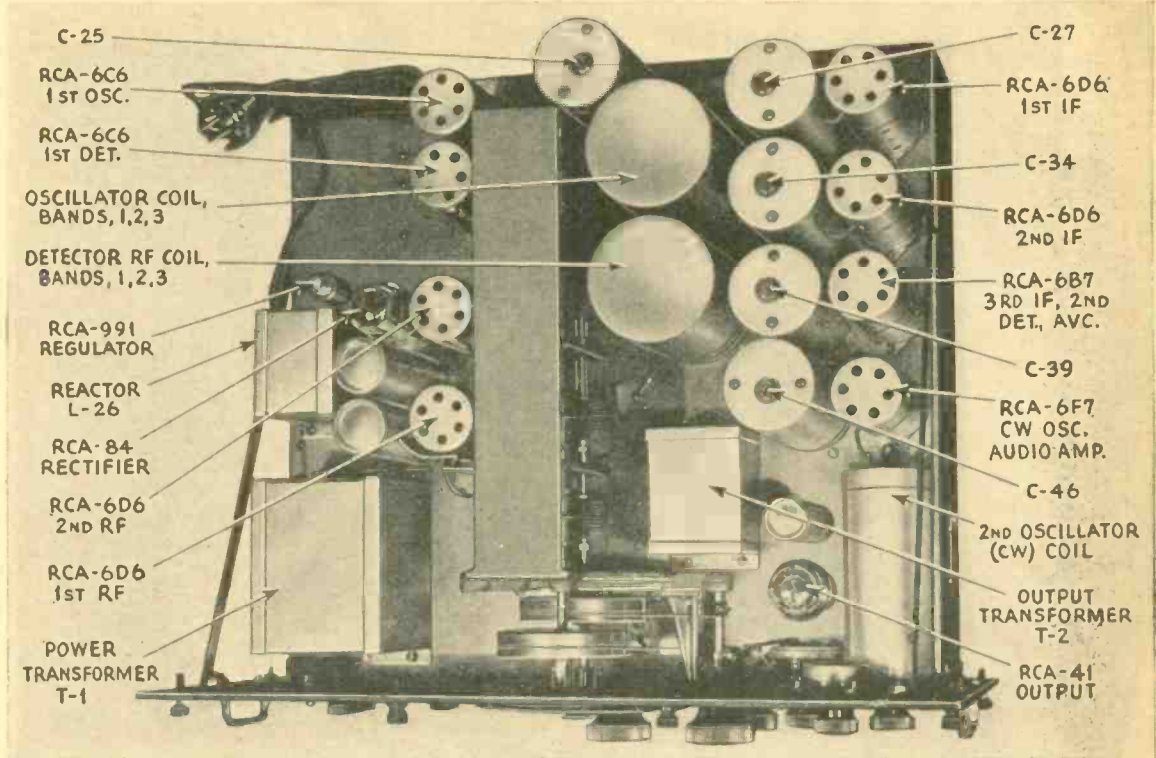

FIG. 1—LEGEND

C1—50mmf. C2, 10, 17, 61—11-40mmf. each.	L11, 12—Osc. Coil, 3 LF bands.
C3, 11, 18, 62—8-19mmf. each.	L13, 14—Crystal input trans.
C4, 5, 6, 13, 14, 21, 22, 47, 49, 64, 65, 66—0.01mfd.	L15, 16—Crystal output trans.
C7, 9, 16, 56, 58, 59, 60—Variable max. cap. 15 mmf.	L17, 18—2nd IF trans. coil.
C8, C23—0.1mfd. C12, 19, 63—800 mmf.	L19, 20, 21—3rd IF trans. coil.
C15, 28, 33, 36—0.01mfd. C20—3mmf.	L22, 23—2nd Det. plate coupling coil.
C24, 31, 38—Trimmers.	L24, 25—Beat (CW) Osc. coil.
C25—Input trans. coil trimmer.	L26—Filter Reactor. R1, 5, 9, 27—1 meg.
C26—Crystal neutralizing capacitor trimmer.	R2, 6—330 ohms. R3, 7—82,000 ohms. R4, 8, 12, 19—5600 ohms. R23, 37, 44—5600 ohms.
C27, 34, 39, 46, 69—Trimmer condensers.	R10, 36—27,000 ohms. R11, 22, 28, 43—10,000 ohms. R13, 20, 35—100,000 ohms. R14, 21—18,000 ohms. R15—5000 ohms. R16—39,000 ohms. R17—33,000 ohms. R18, 26—8,200 ohms. R24—3,900 ohms. R25—225,000 ohms. R29, 33—470,000 ohms. R30—2.2 megs. R31—500,000 ohms. R32—22,000 ohms. R34—680 ohms. R38, 40, 45—56,000 ohms. R39—220 ohms. R41—12,000 ohms. R42—1200 ohms. R46—100 ohms. S1, 2, 3, 4, 5, 6, 7, 8—Single section, 12 contact, band selector switch. S9—Crystal on-off switch. S10, 11—AVC or audio filter switch. S12, 13—On-off switches.
C29, 30, 32, 35, 37, 40, 41, 42, 71, 72, 75—Capacitor packs comprising three 0.1mfd.	T1—Power Transformer.
C43, 48, 51—0.05. C44—200mmf.	T2—Output Transformer.
C45—200mmf. C50—12 mfd. C52—300 mmf.	J1, 3—Phone jacks.
C53—440mmf. C54—2000mmf.	X1—Quartz Crystal, 750 KC.
C55, 57—18mmf. variable.	
C68—CW Osc Trimmer. C70—0.01mfd.	
C73, 74—20mfd. C76—0.25mfd.	
ES—Electronic Screen.	
L1, 2—Antenna Coupling.	
L3—1st RF coil, 3 HF bands.	
L4—1st RF coil, 3 LF bands.	
L5—2nd RF coil, 3 HF bands.	
L6, 7—Detector Coil, 3 HF bands.	
L8—Detector Coil, 3 LF bands.	
L9, 10—Osc. Coil, 3 HF bands.	

Which Is Incorporated Many Advanced Features



- C-25
- RCA-6C6 1ST OSC.
- RCA-6C6 1ST DET.
- OSCILLATOR COIL, BANDS, 1,2,3
- DETECTOR RF COIL, BANDS, 1,2,3
- RCA-991 REGULATOR
- REACTOR L-26
- RCA-84 RECTIFIER
- RCA-6D6 2ND RF
- RCA-6D6 1ST RF
- POWER TRANSFORMER T-1
- C-27
- RCA-6D6 1ST IF
- C-34
- RCA-6D6 2ND IF
- RCA-6B7 3RD IF, 2ND DET., AVC.
- C-39
- RCA-6F7 CW OSC. AUDIO AMP.
- C-46
- 2ND OSCILLATOR (CW) COIL
- OUTPUT TRANSFORMER T-2
- RCA-41 OUTPUT

Top View of Receiver Chassis

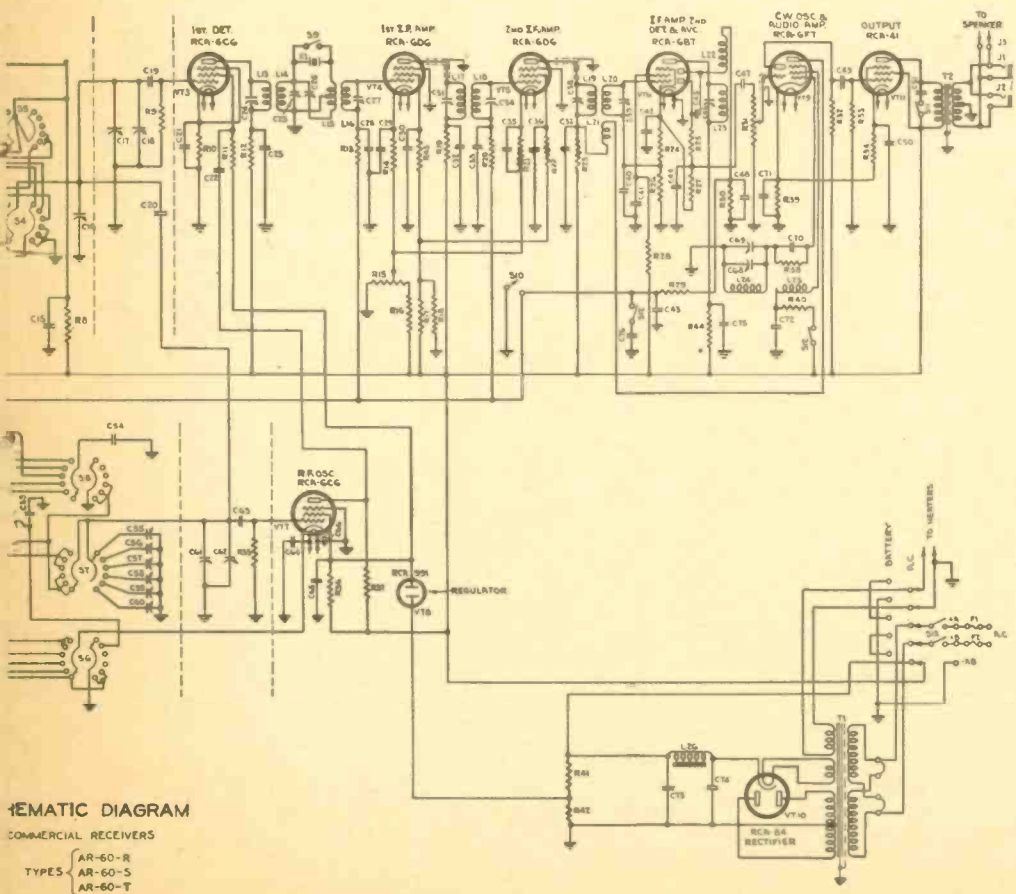

SCHEMATIC DIAGRAM
 COMMERCIAL RECEIVERS
 TYPES AR-60-R
 AR-60-S
 AR-60-T

quency range of the receiver, are in parallel. The coils have been so designed that the unused coil causes negligible loading of the coil in use. The center tap of both coupling coils is connected to a terminal which may be grounded if it is found desirable to do so. The first tuned circuit is provided with a trimmer condenser adjustable from the front panel. This insures the proper tuning of this circuit with any antenna system and with any degree of coupling.

RF Amplifier. The RF amplifier is designed to provide ample selectivity ahead of the first detector for minimizing cross-modulation and blocking effects from strong interfering signals and for obtaining a high degree of image signal suppression. The amplification is adjusted to provide optimum signal to noise ratio by making noise contributions of circuits following the first tube negligible in comparison with the noise contributed by the first RF grid circuit. That is, each tuned circuit in the receiver contributes some noise voltage, but by making the gain of the first tube as high as practicable, the noise contributed by succeeding circuits is unimportant. Only one stage of RF is used on the lower frequency bands, since sufficient gain is obtained and the image response is inherently much better on the lower frequencies because the image occurs at a frequency differing from the RF circuit resonance by a greater amount.

Band Spread. Band spreading is accomplished by means of a separate capacitor gang of suitably small capacity. This capacitor gang is connected in parallel with the main gang at all times and permits adequate band spreading at any frequency in the range of the receiver.

Tuning Inductance. The tuning inductance systems used in the first RF grid, detector grid and oscillator grid circuits each consist of two coils wound on Isolantite forms (Please turn to next page)

first tuned circuit to maintain transmission line balance and to prevent voltages picked up by the transmission line from being coupled to the first tuned circuit. Since the coupling is variable, one value of inductance in the coupling coil is sufficient for a considerable range of frequencies. The two coupling coils, which cover the entire fre-

and tapped to provide a total of six different values of inductance. The second RF circuit utilizes one coil with three taps, this stage being used only on the three higher frequency bands. This system of inductances for band changing gives substantially the same RF selectivity and gain as a good plug-in coil system with the added advantage of ease and speed of operation. "Dead spots" or spots of low sensitivity are entirely avoided by shorting possible resonant circuits in the coil sections which are not in use.

Band-Change Switch. A specially designed gang switch is used so that the necessary inductance changes for the various bands are accomplished by a single panel control. Particular care has been taken in the design of the switch not to add undesired losses in the tuned circuit.

First Heterodyne Oscillator. The first heterodyne oscillator is aligned to track with the RF amplifier at 750 KC higher than the signal frequency, thus producing a 750 KC intermediate frequency in the first detector plate circuit which is amplified further in the IF stages. The oscillator voltage is regulated by the RCA-991 regulator tube to provide maximum frequency stability under conditions of variations in power supply voltage. The maximum possible amount of coupling is used to the detector circuit which will not produce objectionable reaction with the RF circuits. This helps to minimize cross modulation and blocking effects, since in general, blocking of a weak signal does not occur until the voltage from the strong signal on the first detector is about equal to the heterodyne oscillator voltage.

Crystal Control. For operation on a fixed frequency, crystal control for the first heterodyne oscillator can be furnished. This feature is not supplied as standard equipment, but can be incorporated in the receiver assembly if desired. The arrangement consists of a low temperature coefficient crystal operating in conjunction with the first heterodyne oscillator. Temperature control may be provided additionally for cases of extreme temperature variation. By use of this device, the receiver tuning can be accurately stabilized on a predetermined frequency.

Intermediate Frequency Crystal Filter. The first detector plate circuit is tuned to the intermediate frequency and a balanced link circuit is used to couple the first detector plate and first IF grid circuits. A 750 KC crystal is connected in one arm of the link circuit and a neutralizing capacitor which is controlled from the front panel, is connected in the other. The impedances of the coils in this link circuit are designed so that the crystal selectivity characteristic is not impractically sharp. The band width at two times resonant input may be adjusted from approximately 125 to 700 cycles. The band width at ten times resonant input varies from approximately 600 to 2600 cycles. A second control is the neutralizing capacitor controlled from the front panel. By variation of this control, the band width at two times resonant input remains substantially constant but the shape of the selectivity characteristic is varied in such a manner as to cause rejection of certain frequencies. Thus, without affecting the desired signal response, an interfering signal only a fraction of a kilocycle removed from the desired signal may

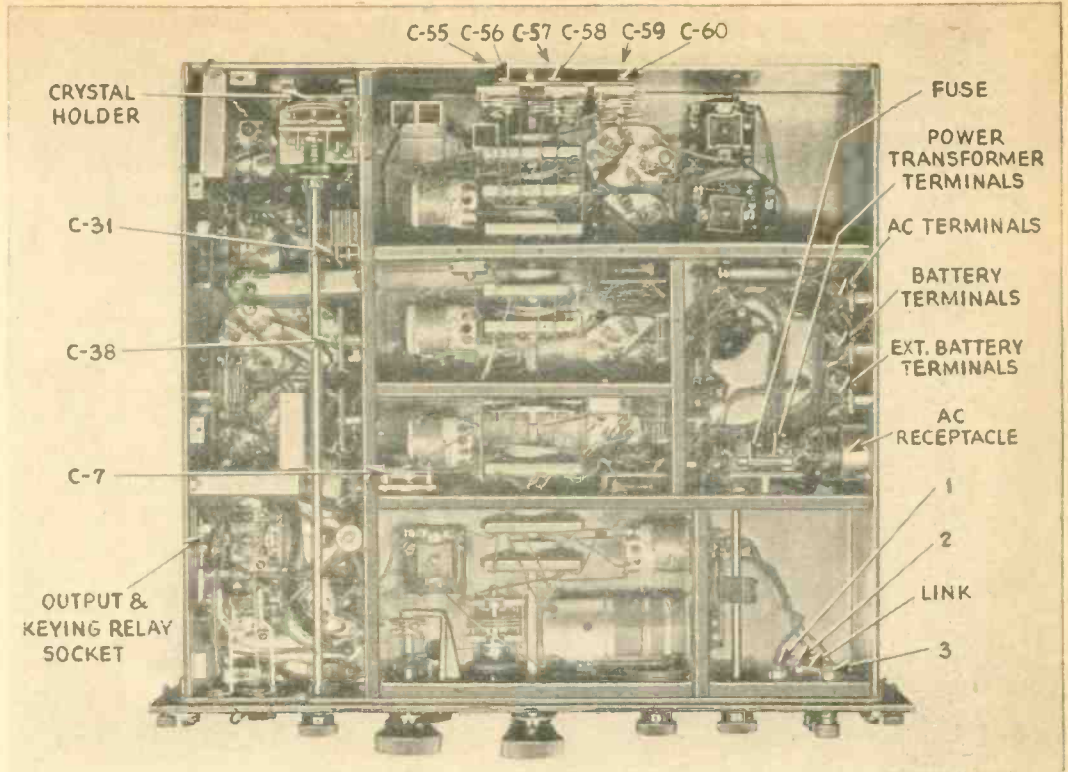

Bottom view of receiver chassis, covers removed.

be rejected. This is shown by the curves of Figure 2. These curves show the amount of the rejection in D.B. of a particular frequency off resonance. The crystal "broad-sharp" adjustment on the chassis (C25) is in the "broad" position for these curves. When in the "sharp" position, the amount of the rejection is increased about 10D.B. These curves also show the change in the band-width at 10, 100 and 1000 times resonant input which occurs with different settings of the "Crystal Selectivity" control. The design is such that introduction of the crystal filter into the circuit produces a negligible change in gain. The use of an intermediate filter preceding the IF amplifier has advantages as compared to an audio filter, in that changes of blocking are reduced by suppression of interfering voltages before they are amplified by the IF system. Atmospheric and tube noises are reduced more for a given frequency-band width, since the audio image signal is highly attenuated.

The audio image signal appears only in

CW reception. This is the signal, on the opposite side of the second heterodyne (CW) oscillator frequency from that of the desired signal, which would produce the same audio frequency in the receiver output as the desired signal. As an example, if two signals differing by 2 KC are received they would produce intermediate frequencies differing by 2KC which would both pass through the IF amplifier if it had a sufficiently broad frequency band-pass characteristic. If the CW oscillator frequency is midway between the two signals, each would produce the same audio signal frequency of 1000 cycles. The two signals therefore cannot be separated with any amount of selectivity in the audio circuits. With sufficient selectivity in the IF circuits, either one of the signals may be received and the other rejected.

Intermediate Frequency Amplifier. Three stages of IF amplification are used. The first two stages use type RCA-6D6 tubes and the final stage utilizes the Pentode portion of an RCA-6B7, the two diode plates being used for the second detector and AVC. The first IF transformer has its primary and secondary tuned and is coupled through the crystal filter link as described above. The second and third transformers have primary and secondary tuned, the couplings being permanently adjusted to produce the desired frequency primary and untuned secondary feeding the detector and AVC diodes.

The third IF stage is not connected to the AVC or manual volume control; consequently, a better AVC characteristic with less overload distortion is obtained. This also

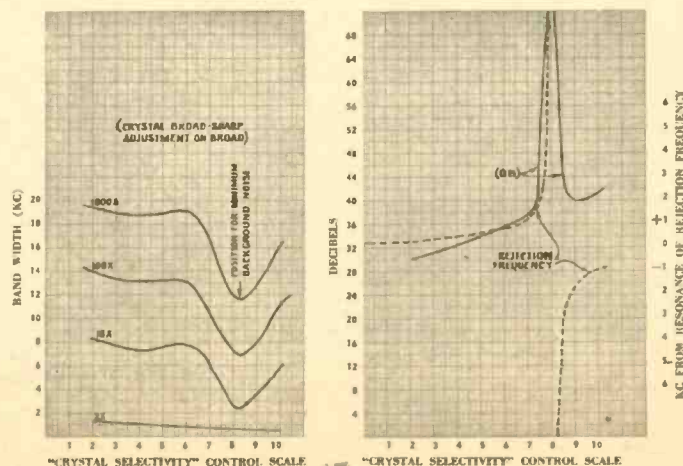

FIG. 2—Curves showing change in band width and rejection (in D.B.) with variation of crystal selectivity control. Note: Control position for minimum background noise will vary with each receiver.

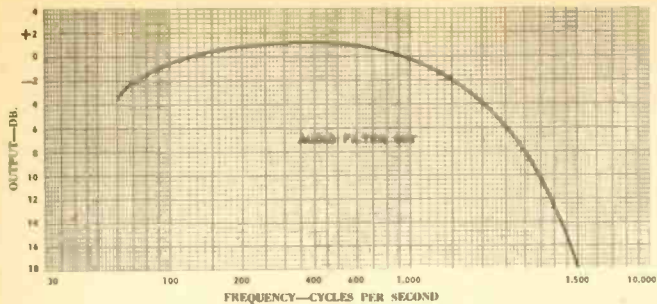

FIG. 3—OVERALL FIDELITY CHARACTERISTIC.

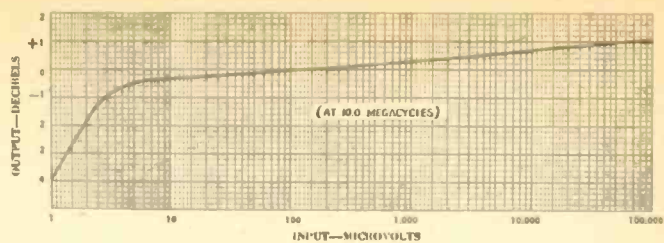

FIG. 4—AUTOMATIC VOLUME CONTROL CHARACTERISTICS.

permits the CW oscillator to be coupled to the grid circuit of this stage, giving a comparatively high detector excitation voltage with small electrical coupling to the oscillator circuit.

Second Heterodyne Oscillator. The second heterodyne (CW) oscillator is the pentode section of an RCA-6F7 and is electronically coupled to the final IF stage. A panel control is provided by means of which the frequency of the heterodyne oscillator and resultant audio beat note may be varied. Particular care has been taken in the design of the circuit constants to minimize oscillator harmonics. The triode section of this same tube is used as an audio frequency amplifier.

Automatic Volume Control. The AVC diode of the RCA-6B7 is biased approximately 12 volts in order to produce delayed action. After the signal voltage reaches this value, a negative voltage is produced in the diode circuit which is fed back to bias the RF and IF amplifiers. The gain of the receiver is such that the AVC starts to control with a signal input of the order of one microvolt. The audio frequency gain is high enough so that maximum power output may be obtained with a 30% modulated signal with the AVC in use. A switch is provided on the front panel to disconnect the AVC.

The second heterodyne (CW) oscillator excitation voltage is just lower than the AVC diode bias voltage so that it does not decrease the sensitivity of the receiver and the AVC may be used on CW telegraph signals equally as well as on modulated signals. The CW switch automatically connects an additional capacitor in the AVC circuit to increase the time constant, so that at normal keying speeds, the AVC continues to function and the background noise does not come up

between characters. This also avoids introduction of irregularities in characters.

Manual Volume Control. Two manual controls are provided; an audio gain control which is employed when the AVC is in use to obtain the desired output level, and an IF gain control for use with AVC "Off".

Output Tube. The output tube is resistance-coupled from the AF amplifier and operates into an output transformer which matches the tube to a 600 ohm line. The center-tap of the output transformer secondary is grounded and an electrostatic shield is provided to maintain balance to ground. The 600 ohm output circuit is provided to facilitate operation over long telephone connections and with the newer type low-impedance phones. Two output jacks are provided so that local monitoring may be obtained at the same time a telephone line or loudspeaker is in use.

Audio Filter. An audio filter "On-Off" switch on the front panel connects a capacitor across the output tube plate circuit resonating the output transformer to approximately 800 cycles and permitting a reduction in noise level on telegraph or phone reception where reproduction of higher and lower frequencies is not required.

Power Pack. The power pack mounted on the receiver chassis consists of a power transformer, rectifier tube, and filter. By a simple wiring change, the transformer is adaptable for operation from 110 or 220 volt, 40-60 cycle supplies.

Shielding. Interstage shielding is provided to insure stability under all operating conditions. Complete external shielding prevents coupling to any portion of the circuit except through the antenna circuit, and minimizes radiation from the oscillators.

Filtering. All power leads are filtered

with resistance-capacitor filter where necessary to eliminate interstage coupling and reduce feedback through the power supply leads. The detector and audio circuits are sufficiently filtered so that no appreciable radio frequency is obtained in the receiver output circuit.

Construction

General. The receiver is arranged for either cabinet or rack mounting, and all operating controls are on the panel. A self-contained power supply is mounted on the chassis for complete AC operation.

Panel. The aluminum panel is 19" long, 10½" high and ½" thick. The following controls are on the front panel:

1. "Main Tuning"
2. "Band Spread" tuning
3. "Band change switch"
4. "Antenna Coupling"
5. "Antenna Trimmer"
6. "Volume" (audio gain)
7. "Sensitivity" (IF gain)
8. "Beat Frequency"
9. "Crystal Selectivity" (in conjunction with this, a switch operated by the same control cuts the crystal in or out of operation).
10. "AVC" switch
11. "CW-MOD" switch, controlling beat frequency oscillator
12. "Audio Filter" switch
13. "Antenna" and "Ground" binding posts
14. "Output" jacks (2)
15. "Power" switch

Adjacent to each of these controls are suitable nameplates clearly indicating the function of the control.

In addition, an equipment nameplate is attached to the panel. When used with a

(Continued on page 34)

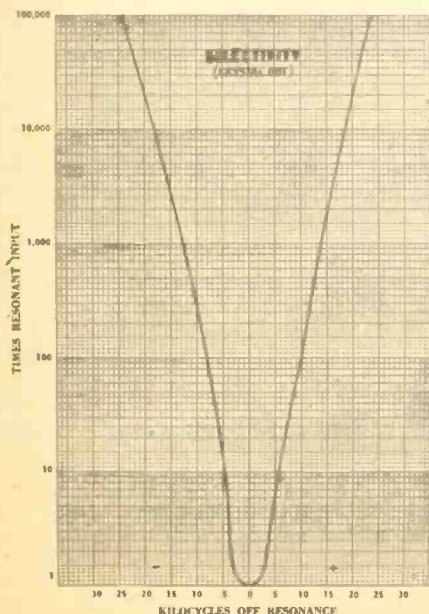

FIG. 5 SELECTIVITY CURVE (CRYSTAL OUT)

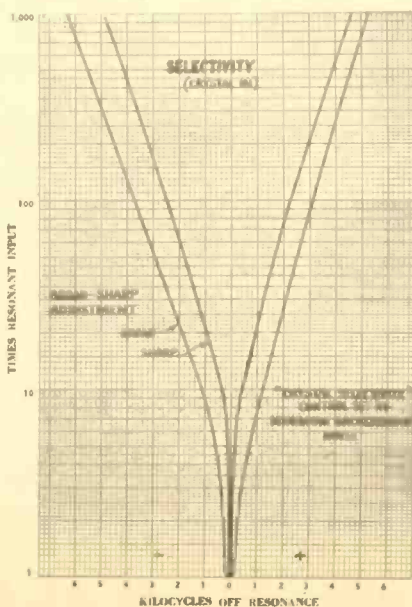

FIG. 6 SELECTIVITY CURVES (CRYSTAL IN)

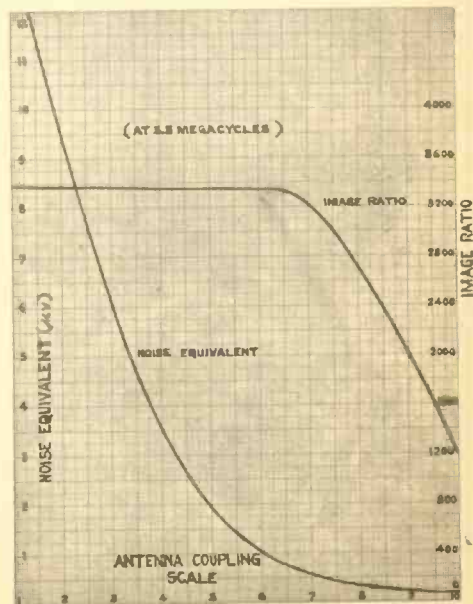

FIG. 7 CURVES OF NOISE EQUIVALENT AND IMAGE RATIO WITH VARIATIONS IN ANTENNA COUPLING.

W7AOF — Mrs. A. S. Moody — Killed

Contact With High-Voltage Plate Lead Takes Life of Well Known Amateur

● The "night network"—that world-wide cobweb of ham stations—always interesting, always colorful, always dramatic—experienced a ripple of tragic horror early this month when one of its beloved figures, W7AOF, Mrs. A. Skene Moody, 47, of Portland, Oregon, was electrocuted at the controls of her transmitter.

There have been electrocutions before and always they have brought shock to the entire fraternity. It is so easy to reach out where 3,000 to 5,000 volts races through the copper bird-cages and sign "30" to the sunshine of life. It is all the more tragic when the thing is done accidentally and the eternal

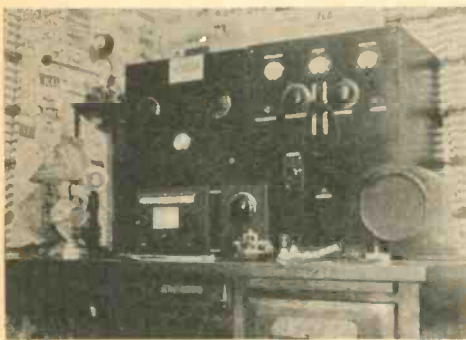

● The illustrations show Mrs. A. S. Moody, W7AOF, of Portland, Oregon, and her receiving and transmitting equipment. A separate relay rack, not shown in the photos, was used for holding the high-voltage power equipment with which

she came in contact, causing her death.

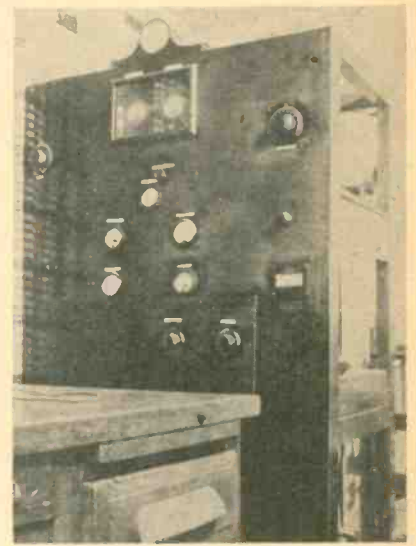

darkness drops its sable wings unexpectedly.

Mrs. Moody was a familiar personality on the air. A licensed radio operator, she had a station that used the world for a playground. What gave her position in radio a double interest was that she was the mother of two radio operators—one in Berkeley and the other in New York with which she chatted daily over her transmitter.

William Moody, the oldest son, lives at Schenectady, N. Y., Alfred Moody, the youngest, is a student at the University of California. Both boys have radio transmitters. The three-way contact was the chief joy of Mrs. Moody's life. All other skeds gave way before it. When she had "spoken" her pals, she took what time was left to chat with other hams in other parts of the world in the paths of the profession.

On the fatal night Mrs. Moody was working station VE2FQ, Sydney Walker, in Montreal, Canada, on CW. She worked with an eye on the clock for she had a schedule with her son, Alfred—one she never missed. She must have keyed her amplifier with one eye on the clock for suddenly she "broke" Walker.

"QRX fr min", she said, "while I switch to fone . . ."

Walker assumed she was having some trouble with her set. He stood by for half an hour, but she never returned. Down in Berkeley, Alfred Moody stood by, waiting for the call from his mother that never came. He called her several times. There was no answer. There was a reason—the best reason in the world. W7AOF was dead.

Reconstructing the accident afterward it appeared that Mrs. Moody had taken hold of an uninsulated clip lead in the modulator unit to remove a wire shorting the secondary of the class B modulation transformer which

was used when the station was working CW. Her heel was on the ground wire which ran along the floor at this point so that she received the full impact of 3200 volts between hand and heel. Death came mercifully quick.

Signe Maki, a maid in Mrs. Moody's home, found her body in the upstairs room of her home, 3433 Northeast Davis street, when she went to take the morning mail to her mistress. This was about 11 o'clock. Doctors and ambulances came then but nothing could be done. It was then that the sad word of what had happened was sent to the two grief-stricken sons.

Mrs. Moody's passing leaves a hole in West Coast amateur radio. Her voice was well known to hundreds of fone operators who liked to "kid" with her over the air. Her interest in radio began when she became a student at the Oregon Institute of Technology in order to obtain a license and communicate with her sons. In 1932 she won her coveted "ticket"—an amateur license. Recently she passed the Federal requirements for the special privilege "class A" license.

Mrs. Moody was born in Auburn, Calif., and moved to Portland in 1910, a year after her marriage. She was a member of the Town Club and a director of the Girl Scouts. Her husband and the two sons survive. Her friends on the air were legion and her log book was filled with QSOs from every part of the globe.

A short time before her death Mrs. Moody was talking with a station at Belton, Mo. This and the Canadian contact serve to fix the time of her death, although she lay beside her dead transmitter for several hours before she was found.

So with sorrow and deepest regret we, of the ham fraternity, list among the "silent keys" that of Mrs. A. Skene Moody of W7AOF.

DX

(Continued from page 19)

with his hook-full of traffic to the Far East. During some months he handled as many as 600 messages . . . some of them several hundred words in length. Messages were mailed to him from people in many parts of the States for transmission to the Orient.

Nothing pleased him more than to know that he had been able to handle traffic for those who could ill afford to pay for it. The missionaries in China relied upon the Colonel to get their traffic through. And he never failed them.

His transmitter was an elaborate affair, built for him by the boys at the Heintz and Kaufman factory . . . Heintz, McAuley, Roebuck, all AAL hams. Old-timers cooperated with him in collecting and dispatching traffic. Every member of the radio club at San Jose was his pal.

The Colonel was a member of the Trans-Pacific Traffic Association, a select group of able amateur operators who were honored with a certificate of membership in the organization only after they proved their worth to amateur radio.

Sitting alongside the big transmitter at W6HM was a tiny two-tube RF receiver. Carmel is a DX haven, you literally don't need a receiver at all to bring in DX at that place. The Colonel became interested in amateur radio while visiting a ham friend on Vancouver Island, British Columbia, where he maintained a summer camp. A small transmitter was built, in which a single 01-A tube was used. With that transmitter he contacted a ham in New Zealand. He later donated the transmitter to the Canadian Government and he was given a Canadian amateur radio license, the only one of its kind ever issued to an American. After he perfected his amateur traffic chain between Carmel and the Far East, things began to hum. He proved the worth of amateur radio to those who previously had no means of rapid communication with relatives thousands of miles away. Everything went along smoothly, until the blow of the Madrid Treaty found its mark. The ratification of this treaty, which the Colonel fought with all his might, wrote the doom to amateur third-party message handling. He pleaded with the amateurs to cooperate with him in urging the Congress to refuse to ratify that portion of the Treaty which wrote finis to amateur third-party message handling. The ratification of the Treaty sounded the death-knell to the major activities of the Trans-Pacific Traffic Association. The Colonel spent months of his time, much of his money, in contacting political leaders at Washington in a frantic endeavor to stop the

(Continued on page 27)

EIMAC TUBES— *More Power Greater Economy*

The EIMAC Tube Handbook

This new 12 page bulletin contains much valuable general information on the design, construction and adjustment of amplifiers and transmitters, in addition to the characteristics of EIMAC tubes. The tube characteristics are presented in the new and exclusive constant-current charts which tremendously simplify the determination of optimum operating conditions for Class A, Class B or Class C operation. Schools and colleges are using the EIMAC constant current CHARTS for classroom projects in predicting tube performance. Instructors are invited to write for a supply of these charts. Write to your nearest EIMAC dealer, whose name and address is shown below, and he will send you a copy.



50T - Price \$13.50 Net
50 watts of available plate dissipation. 30 watts of filament heating power. Only 2.5 uufds. plate-to-grid capacitance.

Filament 5-5.25 V. at 6 A. Rated plate loss 50 W. Amp. factor 13. Max. plate current 125 MA. Cpp 2.5 uufds. Max. Plate Voltage, 3000. Max. Plate Dissipation, 75 watts. Max. Class B Audio Output 375 watts. Cpf 2.0 uufds. Cpf .4 uufds. Base UX 4 pin. Max. height 7 1/2". Max. diameter 3 3/4".

Plate Voltage	Class C RF Output One Tube	Class B Audio Output Two Tubes
1000 V.	75 W.	100 W.
1500 V.	115 W.	150 W.
2000 V.	150 W.	200 W.
2500 V.	185 W.	230 W.
3000 V.	250 W.	260 W.

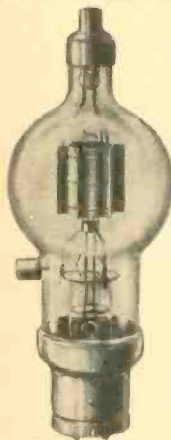

150T—Price \$24.50 Net
150 watts of available plate dissipation. 50 watts of filament heating power. Only 3.5 uufds. plate-to-grid capacitance.

Filament 5 V. at 10 A.; rated plate loss 150 W. Amp. factor 14. max. plate current 200 MA. Cap 3.5 uufds. Cpf 3.0 uufds. Cpf .5 uufds. Base 50 watt. Max. height 10 inches. Max. diameter 3 3/4 inches.

Plate Voltage	Class C RF Output One Tube	Class B Audio Output Two Tubes
1000 V.	150 W.	200 W.
1500 V.	225 W.	350 W.
2000 V.	300 W.	500 W.
2500 V.	375 W.	625 W.
3000 V.	450 W.	700 W.

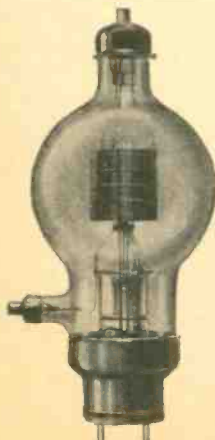

500T
Price \$175.00 Net
500 watts rated plate dissipation. 150 watts filament heating power. Filament 7.5 volts at 20 amps. Amplification factor, 13. Max. plate current, 450 MA. Cpp. 4.5 uufds. Cpf, 6 uufds. Cpf. 0.8 uufds. Base, Special Max. height, 16 1/2". Dia. 7". Normal Class C output at 4000 volts, up to 28 MC, 1350 watts. Max. Class B audio output (2 tubes) 2000 watts. FCC Phone Rating, Class C, 500 Watts. FCC Phone Rating, Class B, 250 Watts Carrier.

The Wise Man Uses the Most Economical Methods for Producing Maximum Results

THERE ARE MANY OTHER FACTORS BESIDES LOW FIRST COST WHICH ENTER INTO THE SELECTION OF VACUUM TUBES FOR YOUR TRANSMITTER IF A MINIMUM COST PER WATT OF ANTENNA POWER IS DESIRED.

EIMAC exclusive design and the use of Tantalum* has made possible transmitter economies never before thought possible.

LOW FIRST COST: No tube with equal power ratings or capabilities sells for a lower price.

LONG LIFE: In Amateur service, only about one tube out of ten terminates its useful life through natural causes. EIMAC design and the use of TANTALUM* definitely eliminate such failures as stem punctures, insulator failures, gas liberated through overloads, etc. The large rugged Thoriated Filament and the complete freedom from gas permits exceptionally long filament life.

LOW EXCITATION: The low values of grid current for optimum performance effect economies in buffer design.

POWER SUPPLY: Power supplies for EIMAC tubes give the greatest power possible with readily obtained transformers, condensers, chokes, rectifiers, etc.

*TANTALUM grids and plates make it possible for EIMAC to guarantee INDEFINITELY against tube failure caused by gas.

REMEMBER: EIMAC Tubes Do a Better Job — Easier

NEW RATINGS FOR THE EIMAC 50T

A Truly Great Tube, With Still Greater Capabilities

FILAMENT VOLTAGE

5-5.25 Volt.

Max. Plate Volt.3000
Max. Plate Current...125 MA
Max. Plate Dissip....75 Watt

CLASS "B"

Audio Output (2 Tubes)

1000 Volts,	106 Watt
1250 " 150 "	
1500 " 200 "	
2000 " 260 "	
2500 " 320 "	
3000 " 350 "	

CLASS "C"

(Single Tube, 75% Efficiency)

1000 Volts,	95 Watt
1500 " 140 "	
2000 " 185 "	
2500 " 235 "	
3000 " 250 "	

EITEL-McCULLOUGH, INC. SAN BRUNO CALIFORNIA, U. S. A.

The New '5D' Superhet!



These Features Tell Some of the 5d Story:

- No plug in coils — efficient band switching and send-receive switch.
- Two tuned r.f. stages on all four bands.
- Low C tuned circuits — all circuits air trimmed and tuned.
- Bliley crystal filter for single signal C.W. and super-selective phone reception without loss of volume.
- Accurately relogging band spread anywhere in its tuning range—hundreds of degrees for each amateur band.
- Covers all five amateur 10, 20, 40, 80 and 160 meter and all S.W. broadcast bands—9 to 175 meters.
- Almost no inherent noise—the quietest yet most sensitive set you've ever operated.
- Sensitivity better than 1 microvolt at all points of all bands.
- Selectivity, just what you want, variable iron-core and air-tuned i.f. transformers.
- Tone what you want—from single signal "peaked audio" to fine broadcast quality.
- Ten new Raytheon 6.3 volt tubes—with 12 tube functions!
- "R" or sensitivity meter.
- All AC operated in one unit with no hum.
- 8" matched Jensen dynamic speaker.
- Polished chromium finish on heavy welded steel chassis fully shielded and temperature isolated for 100% frequency stability.

valuable features than any other professional communication receiver offered at anywhere near its price. It's the ideal receiver for amateurs.

Available from your jobber, the fully laboratory-assembled and tested 5D, complete with ten Raytheon tubes, Bliley crystal and Jensen loud speaker, RCA and Hazeltine licensed, is priced at \$109.80 net to amateurs.

NEW PARTS



17E - 500 Ma. 1 Kw. R.F. Choke

An extremely efficient plate choke capable of carrying 500 ma. continuously at 2000 volts or more for 10 to 160 amateur bands. Has D.C. resistance of 15 ohm, inductance 2.5 m.h., distributed capacity approximately 2 mmf. Provided with two terminal lugs and one mounting screw, net to amateurs 96c.

17G Crystal Auto Transformer and Shield

Designed to materially increase gain and improve performance in single-signal superhets by providing proper crystal impedance match. Requires no circuit tuning adjustment. Supplied with aluminum shield, mounting screws, grid lead and grid clip. Net to amateurs, 60c.

6F Steatite Socket for RK-28—RCA 803

Meets the need for a low loss but inexpensive socket for the new large five-pin transmitting tubes. Steatite base with large spring steel reinforced contacts with soldering lugs and two mounting holes on a 2" diameter. May be mounted above or below chassis. Net price to amateurs 90c.



Jones-Silver "Super Gainer" Three Tube Superheterodyne

Designed by Frank Jones, technical editor, "RADIO," and McMurdo Silver

The three tube Super Gainer with double R.F. and I.F. regeneration gives results almost equalling those of expensive factory built superhets.

Its sensitivity is unlimited, exceeding even that of the highest priced receivers. Its selectivity is controllable—anything up to practically single-signal.

The circuit uses a 6C6 regenerative first detector, 76 H.F. oscillator and 79 as regenerative second detector and audio stage with Aladdin iron core I.F. transformer. The mechanical assembly is of the most advanced communication type, with all parts arranged for the shortest direct leads for wiring. It will immediately give results no other set at its price can touch.

Price, fully assembled, wired and tested, with one pair of coils for 80 meter amateur and 49 meter broadcast, \$23.40 net.

Add for four additional pairs of coils to cover 10, 20, 40 and 160 meter amateur and all short wave broadcast bands, \$4.50 net.

Add for resistor, cord and plug, two electrolytic condensers and choke for complete A.C. or D.C. operation, \$4.50 net.

McMurdo Silver Corporation

3362 N. Paulina Street, Chicago, Illinois

Enclosed 10c for 32-page Manual of Design, Construction and Operation of new 5D Superhet.

Send free circulars on 5D Superhet, Jones-Silver "Super Gainer," and R9+ Antenna.

Name

Address

City..... State.....

11-RM

McMURDO SILVER CORPORATION Division of G.P.H., Inc.
3362 N. Paulina St. Chicago, U. S. A.

Scoop! . . . R9+ ANTENNA

The new R9+ Antenna not only eliminates noise, but increases volume of all s.w. stations from 4 to 5 times. Easy to put up, and costing only \$8.85 net, it is the first tuned short wave antenna available. It's like adding a stage or two of r.f. to any standard all-wave receiver! Check and mail the coupon for complete details.

600 Watt Amplifier

(Continued from page 9)

The plate current was easily loaded to 500 MA with approximately 750 watts output at slightly over 1 KW input. The tube ran without color at 300 MA, which is near its recommended value of 275, and six 100-watt lamps were illuminated to full brilliancy when used as a dummy antenna load.

The plate coil of the final amplifier shown in the picture consists of 9 turns of No. 10 wire, 3 1/2-in. diameter, about 6 1/2-in. long. The grid coil consists of 6 turns, 2 1/2-in. in diameter, 3 inches long. Due to the higher input capacity of this tube, the grid coil should have a little less inductance than when one or two 150T tubes are used.

The plate tuning condenser is a home-made affair, using aluminum plates, spaced 1/2-in. apart. The rotor and stator units are made of 5-in. x 12-in. pieces of 14 ga. aluminum, bent into U-shaped pieces. A silk fish-line or dial string is used to vary the rotor position; a knob and a 1/4-in. shaft under friction is used as a means of winding or unwinding the string. This condenser is very economical to build and it never flashes over. It is of the split-stator construction, in that the rotor interleaves two stator sections.

The neutralizing condenser is made from two similar pieces of 14 ga. aluminum, 4-in. x 9-in., bent into U-shapes, 3 1/2-in. x 4-in. This gives a plate spacing of 1-in., which is ample to prevent flashover. By using only two flat plates, sufficient capacity could be obtained with 1/2-in. spacing and a total overlap of 4-in. x 4-in. The stator plate is secured at one corner to a 3-in. stand-off insulator by means of a machine screw. The rotor is mounted on a similar insulator by means of a Johnson heavy duty coil plug and jack, designed to fit these insulators. The jack spring has good tension and the N.C. condenser therefore stays in position, if the transmitter is not subjected to vibration.

With the wide condenser plate spacing, plate modulation can be used without danger of flash-over, even with very light antenna loading. Coupling to an antenna is made by means of a No. 12 twisted pair, with a 1 or 2 turn loop link coupled to another tuned circuit to which any antenna can be connected.

For CW operation the power gain of this stage runs between 7 and 12, depending upon the allowable output and plate dissipation. A power gain of 9 is about as high as can be figured for an output of around 600 watts on 20 meters. For phone operation the grid excitation must be higher, but the plate load is lower, consequently a power gain of around 4 to 6 can still be figured on. These figures seem to be fairly high for operation at this frequency.

For CW operation a 53-45 exciter driving a pair of 10s or 801s will provide sufficient grid excitation to the HF300. The buffer stage should be operated with approximately 700 volts on the plate. For phone operation a 50T or 211D or H tube is recommended. The modulator should supply about 400 watts of audio power.

Next Month!

New Data On Phone Receivers, By Frank C. Jones . . . one of the many unusual features which will make the December issue the best ever. Don't miss it!

DX (Continued from page 24)

damaging third-party message clause from being written into the Treaty. Aroused by his protest, Washington investigated, made further inquiry. But those in amateur circles who opposed the Colonel reported that they saw no reason why the Treaty should not be ratified as written. Thus a Senate Committee reported it favorably, the Congress signed it, and the law which spelled the doom of one of the greatest humanitarian services ever rendered by the amateurs aroused the Colonel to action.

It was he who first conceived the idea of an honor award to amateurs who worked all continents. "WAC" it was later called. And many of you DXers who proudly hold that certificate will know, for the first time, how it all came about.

● W6EGH, Wallie Gee, that dyed-in-the-wool DX boiled owl, had not been on the air for weeks, but one night something very strange happened. He walked into the shack, turned on the receiver and transmitter by mistake, sat down, very annoyed, at his receiver, plopped the cans on his head . . . and just waited. Didn't move the dial on his Pro more than five degrees . . . after about two minutes he calmly begins calling EA3EG . . . yes, this was on 40. Got the EA alright, and after a 100 per cent ragchew he turns off the receiver and transmitter and says, "Good night." Oh, yeah, EA3EG only gave Wallie . . . R-9. W6EGH will be on again in a few weeks, I think. Ho-hum.

●●● In one of the paragraphs last month I asked what had become of W6WB, W3BBB, W3ANH, and W5ATF. Got a rise out of W3BBB, Len Haeseler. He kicks through with the following information regarding the above quartet: W3ANH is temporarily "regusted" with radio and is off the air indefinitely. Almost sold all his equipment, but W3BFH came to the rescue and induced him to at least keep the stuff. Claims he gets enough radio at RCA Victor, where he is an engineer. About W5ATF . . . Buck has a job on the road and only gets home about once a month or so. Looks as if he won't be on very much this winter. For W3BBB . . . Len has moved to a new QRA just outside of Reading, Penna. Says 3BBB, "This new spot is sure a honey for

(Continued on page 28)
(Bottom of left-hand column)



Osockme, Japan.
October 23, 1935.

By Wireless Cable, To:—
Hon. Editor of "RADIO",
Pacific Building,
San Francisco, California.
Kind Sir:—

This is no time for Scratchi to make foolishness. Nor are Scratchi in a state of mind to make such kind of comment. Dark pall hang over all of Japanese atmosphere here and entire nation of amateurs are deeply regretting loss of great Number One Pal Amateur, Colonel Foster. On every amateur kilocycle word are going forth of such disaster, because Colonel Foster have great host of friends here in land of the rising sun. Japanese laws here forbid of amateur message handling but all of Japanese amateurs have for many long year intercept strange staccato signal of W6HM and we have many times hear hundreds of kindly messages exchange between Colonel Foster and brother amateurs in China and elsewhere.

We have many times make contact with him for wonderful rag-chew and his signal will be greatly missed from regular spot on dial where he were always found.

He were great man, Hon. Editor, and Scratchi and all brother Japanese amateur send deepest sympathy. It were shocking blow to all of us over here. Colonel Foster were very fine operator. He never send too fast nor too slow. He maintain same sending speed hour after hour and he never seem to tire when he were helping his friends here in Far East to make contact with loved ones in other parts of world. We have make check mark on tuning dial on receiver here where W6HM signal always were heard, and every time we pass over such place on dial we will think of great warrior who were willing to fight entire world to help make better places for amateur to operate in.

Scratchi make formal request to you, Hon. Editor, that you begin to make publication of regular monthly serial article on life of great Colonel and tell all amateurs of everything he did from time he first become radio ham. He never speak about himself which he perform.

Maybe when brother amateurs read such writings they will also become imbued with same spirit which Colonel Foster have. It will be very good thing for amateur radio if few more such men as him were in this fine ham radio game which we are in.

Scratchi will send you regular letter next month, Hon. Ed., and forthwith I make closure for this month. My heart are broken into many small pieces now and I must first try to patch such pieces together again.

I sympathize with you in your great loss, Hon. Editor, and my only consolation come from fact that I were fortunate enough to have had opportunity to read Colonel Foster's writing in good magazine "RADIO" for two year past. Whenever Scratchi need inspiration I will again make re-read of such writings, because such have never before been seen in other radio magazine. Me think it are mighty good thing for all other amateur to also make re-reading of such.

Your faithful friend,
Hashafisti Scratchi.

Seriously—

—The field of Practical Radio Engineering is as crowded as an air-conditioned church on a hot Sunday.

—But there's a job in every town—waiting for a good man to fill it.

—That condition exists in almost all trades and professions. Always has. Of the many men in the business only a few are capable. These men are in demand.

—In Radio the *capable* man is the *trained* man. The man who plans his life as carefully as he plans an r-f oscillator. The man who budgets a part of his time to study.

—There is room for this type of man. In fact, there is a NEED.

—If your position in Radio isn't as secure as you'd like to make it, write me, will you? I'll go into it personally.

P. S. LUCAS.

Edison Electrical Schools

1740 UNIVERSITY AVENUE
BERKELEY, CALIFORNIA

Announcing !!
Our "Easy Payment" Plan

NOW—Radio Amateurs and Shortwave Listeners, living in any part of the U.S.A., may buy modern, standard shortwave receivers on extremely easy terms. We NOW offer our really "Easy Payment" Plan for the Radio Amateur and Experimenter, so you and your friends may purchase a really GOOD receiver out of your budget. Our plan enables you to equip your station with the latest type receivers, thus greatly increasing your pleasure and interest in Amateur Radio.

JUST THINK—for only a few dollars down payment, you may have your choice of the finest receivers on the market. You can equip your station with that fine new receiver you thought you couldn't afford. Really, OM, you can't afford NOT to buy your new set—our plan works so well for you.

WHY WAIT? Every day you put off ordering, you are without good reception that much longer. Everybody is doing it—buying up-to-date equipment. It's time for you to live up your shack with good sips. Get "On the Air," OM. Write us for further information on our really "Easy Payment" Plan.

HINDS & EDGARTON
19 S. WELLS STREET CHICAGO
W9APY W9WR

7000 Kc XTALS

New thick C&S cut high activity, single freq. response, guaranteed \$225 p.p. close to specified frequency.

80M - 160M - C&S Cut - \$2.00 p.p.

C&S XTALS
836 E. WEBER AVE. STOCKTON, CALIF.



BLILEY CRYSTALS

"World's Finest Crystal"

Guaranteed to improve your crystal stage efficiency and give you perfect satisfaction and performance! Holder free with each crystal!

BC3 (within 5 kc.—3.5 or 7 mc.) \$3.95
LD2 (within .1%—1.7, 3.5 or 7 mc.) \$4.80
Sent C.O.D. if desired—no money down.

Inquiries answered promptly. Folder free on request.

ORDER DIRECT FROM
HAM PRINT SHOP—W8DED
53 East Seventh St. Holland, Mich.
We Sell EIMAC Tubes and ARRL SUPPLIES

new! KELLOGG TRANSCEIVER HANDSET



A better all-around Transceiver Handset! Highly efficient single-button Kellogg microphone, super-sensitive Kellogg receiver. Easy to hold. Fits the face. ● Microphone has greater sensitivity and "flatter" response curve than the usual "mike" of this type. Precision built, as are all Kellogg products. Gold plated diaphragm. Especially processed carbon. ● Receiver is the product of 35 years experience building telephone apparatus. Bi-polar magnet of cobalt steel. Cadmium plated diaphragm. Small, compact, easy on the ear. ● Simply and ruggedly constructed and light weight. Cast aluminum triangular handle. Baked black enamel finish. Has 6-foot, 4-conductor, 18-strand tinsel cord of telephone quality. ● You will be proud to own this unit. Better yet, it's not expensive. Code No. 38-A, 70 ohm receiver, list price \$10.00. Code No. 38-B, 2000 ohm receiver, list price \$11.

KELLOGG SWITCHBOARD & SUPPLY CO.
1070 W. Adams St. CHICAGO, ILLINOIS

\$1 brings you the next four issues of "RADIO"—Subscribe NOW.

QSL CARDS

Stamp for Samples

W8DDS PRINT

2156 W. 80th St.

Cleveland

More Distance • Less Noise

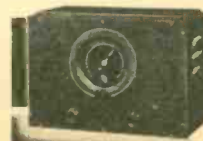

MILLER PRE-SELECTOR

J. W. MILLER COMPANY
5977 So. Main St. • Los Angeles, Calif.



X-mitting CONDENSERS

... Fine and Superfine

For that "ham" transmitter you cannot do better than Aerovox round-can oil condensers. Cost less ... because of Aerovox mass production. Stand up best ... because of Aerovox engineering. No wonder these *fine* units outsell all others.

But if you want *super-fine* condensers for commercial grade transmitters ... to stand up under the most gruelling continuous service ... lowest final cost, then your logical choice is Aerovox rectangular condensers.

Round-can oil-filled. Most compact. Pure linen paper. Hermetically-sealed; positively seepage-proof. High-tension terminals. 1000 v.—1, 2 and 4 mfd.; 1500 v.—1 and 2 mfd.; 2000 v.—1 and 2 mfd.

Rectangular-can oil-filled. Finest linen paper dielectric. Oil-impregnated oil-filled. Clamped section avoids plate flutter. High-tension pillar insulators. 1000 to 5000 v. ratings. 0.5 to 4 mfd.

Compare quality ... compare prices ... compare performance of units out in the field. That's all we ask!

DATA New 1935 catalog covers complete condenser and resistor line. Also sample copy of monthly Research Worker. Meanwhile, see actual units at local supply house.



CORPORATION

84 Washington St. Brooklyn, N. Y.

DX (Continued from page 27)

reception, and guess it will be just as good for transmitting." There is no QRM near him except a 66,000-volt transmission line two blocks away ... but the funny thing is, the only place the high line bothers me is in the BC band, consequently the BCLs don't listen to their sets very much.

● Listen, you fellows, most of this page seems to be made up of more or less West Coast DX news. We want this page to cover the world. It will take a little time, but with the help of all you DX men we can present something that will be very much appreciated by all. Send along photographs, notes of personal interest on DXers, humorous happenings in regard to DX, data on antenna systems ... in fact, anything that you think would be interesting to the DX key-pushers. Let's get more representation from the East Coast, Europe, Asia, Africa, both south and north. South America, Australia, New Zealand and all the out-of-the-way places.

● Last month in this column I mentioned the fact that I had worked a new W9. Someone took some sort of a crack at that remark, so this month I am listing my new DX ... worked two new W1s and one new W3 ... ummm-ummm, really getting out now!

R.F. Chokes (Continued from page 15)

C is the capacity under measurement, Cf is the capacity required to tune to the fundamental and C2f is the capacity required to tune to the harmonic.

Unfortunately, little work had been done in the development of Piezo-Electric oscillators, or any form of oscillatory circuits which were capable of a frequency adherence to a few cycles in a million. Measurements made in the writer's laboratory were conducted with an accurate frequency standard comprising a 100 KC crystal with two buffer amplifiers, a heterodyne frequency meter and General Radio precision condensers, the accuracy of the driver frequency being better than one part in a million from week to week.

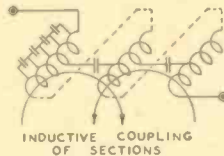

FIG. 2

Showing how the distributed capacity in the coil can be visualized.

Fig. 2 illustrates in a simple manner just how the distributed capacity of a coil in the modern choke can be visualized. Each of the individual capacities so designated are extremely small, but the effect of these capacities, in conjunction with the turns of wire associated with them and the adjacent turns of wire which are inductively coupled, and the distributed capacities with them determine, to a very large degree, the ultimate performance of the choke and decide where the choke may be used without modification in a number of frequency bands, or whether the performance of the choke is limited to one band only.

The use of good chokes is by no means a "cure-all" for every transmitter trouble, but it has been noted both on the broadcast band and on all amateur bands that some transmitters are using choke coils of such characteristics that the RF current flowing through them is of such magnitude that the choke must be wound with exceptionally heavy wire, far in excess of that required to carry the direct current flowing through it. Investigation by the writer indicates that a current carrying capacity of 300 circular mils per ampere is adequate and will provide an insignificant temperature rise if the choke is properly designed. Let it suffice to say that a number of turns of wire wound at random on a tube is not a good choke in any band, let alone on all amateur frequencies.

Effect Of Choke In Circuit

A choke coil necessarily having distributed constants is subject to standing waves. The effect of standing waves may be observed by providing an experimental coil with a number of taps and connecting in circuit a thermogalvanometer in series with the coil at tapped points. From this the current distribution can be studied and the performance of the choke coil as a unit closely observed over the range of frequencies upon which it is to operate. Among such effects which may be studied are the use of different types of tubes in conjunction with the choke and the effect of tuned circuits of various LC ratios. The peaks and valleys in the impedance characteristic of the coil can be plotted readily against frequency and "dead spots" where an oscillator will stop oscillating or where the choke will present practically no impedance with a consequent high percentage of watts loss may be observed. Since a study of this nature is somewhat out of place at this time

(Continued on page 29)

AMPERITE HIGH LEVEL VELOCITY

Operates **WITHOUT PRE-AMP**
HIGH IMPEDANCE—2000 OHMS
THIS MICROPHONE IS HIGH ENOUGH IN IMPEDANCE TO OPERATE DIRECTLY INTO GRID ... BUT NOT HIGH ENOUGH (ONLY 2000 OHMS) TO INTRODUCE SERIOUS LOSSES IN LINE UP TO 200'.

Replaces condenser and crystal mikes. No changes necessary. Eliminates input transformer and its losses. Eliminates hum trouble and feedback.

ELIMINATES HUM TROUBLE



MODEL RB-H, for speech and music, LIST \$42.00 with coupling. MODEL RS-H, for speech, but can also be used for music, LIST \$32.00 with coupling. Write for Bulletin H.

New! POSITIVE-AND-SMOOTH-ACTION STANDS

Positive, non-sliding, ball-bearing clutch! Will never wear out ... never require adjustment. WILL NOT "CREEP". Tightens with only 1/2 turn of clutch. Mike can be rotated without loosening clutch. SMOOTH, PNEUMATIC-LIKE ACTION up and down. A model for every purpose. WRITE FOR ILLUSTRATED BULLETIN S.



AMPERITE Company 561 BROADWAY NEW YORK

AMPERITE MICROPHONE

Old Issues of "RADIO" Now Available for the First Time in a Year

● After buying-in a small stock of old issues of RADIO from subscribers and readers, all issues being in perfect condition, we can now offer a limited number of complete volumes. Those who are on the waiting list for these old volumes, and those who have intended buying copies of previous issues, are urged to send their orders *immediately*.

The following copies are now on hand:
 1933 October, November, December, 50c each
 1934 Any issue from January to Dec. 25c each
 1935 Any issue from January to Oct. 25c each

Complete set of above, 26 copies in all, \$5.00, post-paid in the U. S., \$2.00 additional postage (for all 26 copies) to Canada and Foreign Countries.

If your order reaches us after these copies are sold, your money will be promptly refunded.

"RADIO"

Pacific Building, San Francisco, California

Sh! — Silence!

That's what some members of the family would like to tell you, but out of consideration for your enthusiasm they hold back.

CANNON BALL HEADSETS

You will get clearer reception of all foreign programs and you will not disturb the rest of the family.

Made by America's oldest manufacturer of headsets

Heavy bar magnets, double pole, aluminum cases, D. C. resistances of 2000, 3000 and 5000 ohms. Sturdy construction, sensitive and faithful in reproduction.

Sold everywhere in America

C. F. CANNON CO.
SPRINGWATER, N. Y.

\$1 brings you the next four issues of "RADIO"—Subscribe NOW.

"I'll Pay a Few Cents More for a SPRAGUE ANY DAY!"



"Remember," writes a successful serviceman, "if filter condensers fail to supply the proper voltage (as many 'bargain' condensers do) nothing about a radio can be wholly right. Other essential parts will work far below their standard of efficiency.

"I was surprised to find what a whale of a difference Sprague Condensers actually made in pepping up the performance of 'sick' sets. That's why I use 'em on every job. Take it from me, they're cheaper in the long run—and they've helped me build a real reputation for getting better than average results from the average radio set."

Made in a complete line for every radio service and amateur need.

Sprague Products Co., North Adams, Mass.

SPRAGUE CONDENSERS

Made Right **SPRAGUE 600 LINE** Priced Right

BIG 1936 WHOLESALE



CATALOG FREE

164 pages—Radio, Electrical and Refrigeration Equipment at lowest net prices. A catalog of great value to every dealer, service man and amateur. Complete sets, parts, amateur and commercial apparatus. Write today.

BURSTEIN-APPLEBEE CO.

1012-14 McGee St. Kansas City, Mo.

A NEW BOOK—Second Edition of FUNDAMENTALS OF RADIO

(426 pages 6"x9", 430 figures)



By Professor R. R. RAMSEY, Ind. Univ.

Revised, enlarged, repaged, reprinted. New cover. New subjects Multi-electrode Tubes; A, B and C amplifiers; and Cathode Ray Television. Radio theory and practice brought up to May, 1935. Problems and questions on each chapter.

"This is not in any sense a 'how to make it' book or a compilation of various 'hook ups.' Rather it is a solid, meaty exposition of the principles underlying the many phases of radio." Scientific American.

EXPERIMENTAL RADIO

By the same author

You have heard of the original radio manual of experiments. Get it. Prices: Fundamentals \$3.50; Experimental \$2.75 post paid.

Your check, postal order or C.O.D. brings 'em

RAMSEY PUBLISHING CO.,

Bloomington Indiana

R.F. Chokes (Continued from page 28)

it is hoped that this subject may be treated in detail at a later date.

In order to obtain a sufficiently high amount of inductance with a very low distributed capacity, the following general construction has been arrived at as being the most satisfactory. These results have been greatly substantiated by measurements and tests made in the Naval Research Laboratory as early as 1927 by Crossley* and by the writer in 1925. The total inductance should be split-up in a number of sections which should be sufficiently spaced in order to minimize capacity coupling between sections, but provide a certain amount of inductive coupling which may be regarded as "free inductance". The weave of the wire must be such that the adjacent turns are not next to its preceding or following turns, otherwise unnecessarily high distributed capacity will result. The spacing between coils may be such that possible arcing between sections due to standing waves or DC potentials is eliminated. The leads between sections must be brought off in such a manner that there is no possibility of flashover from the outside lead to the inside of the coil.

* See "Proceedings" IRE, Jan., 1927, p. 28, by Crossley. "Wireless Age", Aug., 1925, by Fortington.

Quiet Amplifier Tubes

(Continued from page 17)

charge is formed, as is the case in amplifying tubes, the fluctuations in space current are decreased and the shot noise becomes less prominent. If complete temperature saturation of the space current could be obtained, the shot noise would be zero. When an oxide-coated cathode is used fluctuations of a larger magnitude are superimposed on the shot effect. These fluctuations are greater at low frequencies and have been attributed to a state of flux and change in the activating material on the surface of the cathode. This disturbance, which has been called the "flicker effect," also is reduced by the space charge.

Positive ions emitted from the cathode or produced by ionization of the gas within the tube are very effective in producing fluctuations in the space current of an amplifier tube. While its own charge contributes little to the current, one ion may cause the current to change by an appreciable amount on account of the hundreds of electrons which are liberated by it during its flight through the space charge region. With modern tubes provided with oxide-coated cathodes working at relatively low temperatures and having a very high vacuum the effect of the ions should be small.

(Continued on page 31)

FORMS CLOSE ON THE 10th OF MONTH

RATES 10¢ PER WORD PAYABLE IN ADVANCE

CLASSIFIED RADIOADS

RECEIVER FOR SALE! Tuned RF using a 33 and two 32 tubes. Real DX receiver for the CW man. Highest bidder by December 10th gets it. Write to W8DED, Holland, Michigan. (DC throughout.)

RECEIVER SCHNELL 3 TUBE, only \$9.95! (Heard all continent at least 6 times.) First buyer gets set at once. (DC throughout.) Write W8DED, Holland, Michigan.

Transmitter; Tritet, 210 Buffer, PP210 Final, Six Meters. Table Style, \$55.00. Bargain.

QSL SWL Cards, neat, attractive, reasonable. Samples free. Miller, Printer, Ambler, Penna.

FOR SALE—Complete Jones 1/4-k.w. Controlled Carrier Transmitter as described in this issue. \$195.00, less mike. Has all tubes, as shown, and coils for 75-80 band, also crystal. Frank C. Jones, 2037 Durant Ave., Berkeley, Calif.

YOU DEMANDED A New CONDENSER

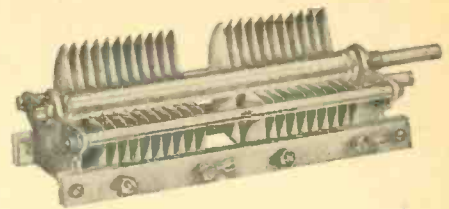

Here it is!

You Asked For It! Now You Have It!

THE NEW MIDWAY CONDENSER

(PICTURED ABOVE)

- ★ Double Spacing—Rounded Plates
- ★ Mycalex Insulation
- ★ Midway Frame
- ★ Small in Size—Big in Performance
- ★ Embodies Every Cardwell Patent and Constructional Feature!
- ★ Increased Flashover Voltage
- ★ 100 mmf.—Each Section

CARDWELL has developed 29 new condensers in past months—all sizes, frames, and capacities—single and double. The complete CARDWELL line is fully described in a New Catalogue. It's yours for the asking.

THE ALLEN D. CARDWELL MANUFACTURING CORP.

85 Prospect Street

Brooklyn, N. Y.

CARDWELL CONDENSERS

Sensational

NEW INSULATED RESISTORS

Metallized **IRC**

Radio's most important resistor development! Insulated against shorting—humidity—opens—breakage. Famous Metallized resistance principle. See them at your jobbers. Write for catalog.

INTERNATIONAL RESISTANCE CO.
Toronto, Canada Philadelphia, Pa.

\$1 brings you the next four issues of "RADIO"—Subscribe NOW.

BUILD THIS 10-TUBE PROFESSIONAL SUPERHET AND SAVE OVER 50%



9 to 175 Meters
"RADIO-SILVER"
HIGH-FREQUENCY
SUPERHETERODYNE

This new "RADIO" SILVER Superhet—designed by McMurdo Silver, Frank Jones and fifteen leading manufacturers—brings you

- Two tuned r. f. stages on all four bands.
- Ten Raytheon tubes.
- Four low-C tuning bands, 1700 to 33,000 kc. (9 to 175 meters).
- Ample Crowe band spread tuning anywhere in its range.
- Bliley Crystal single signal filter that doesn't cut volume.
- All A. C. operated—one unit—no hum.
- 8-inch Jensen concert speaker—and phone jack.
- Polished chromium welded chassis.
- Air tuned Polyiron i. f. transformers.
- Separate r. f. coils positively switched for each band—all Hammarlund air trimmed.
- Sensitivity 1 microvolt and better.
- Selectivity just what you want—variable 50 cycle to 10 kc.
- Amplified automatic volume control.
- No inherent circuit or tube noise—lets you copy signals now lost in noise.
- Wired with made-up color coded cable—requires no circuit tracing, or even a diagram.

HERE'S the latest in high-frequency superhets—one that you can assemble, test and align in one evening at home. It's fun to build . . . you'll save money . . . and boy, will you get a kick out of its amazing performance!

**START FOR AS LITTLE AS \$7.30
BUY THE PARTS AS YOU BUILD!**

The 32-page "HOW TO BUILD IT" Book (sent for 10c, stamps or coin) tells the whole story of 1935's outstanding communication receiver. You can build and align it in a few hours . . . or you can buy its standard parts from your local jobber as you build, if you haven't already got many of them. Now is the time to get ready for the new DX season.

SPONSORED BY

Bliley Piezo Electric Co., Crowe Name Plate and Mfg. Co., Hammarlund Mfg. Co., Chicago Transformer Corp., Yaxley Div. of P. R. Mallory Co., Jensen Radio Mfg. Co., Sprague Products Co., Continental Carbon Co., Ohmite Mfg. Co., Readrite Meter Works, Raytheon Production Corp., Alladin Radio Industries, Inc., Steel Box & Display Co., Filtermatic Mfg. Co., McMurdo Silver Corp.

SEND 10c FOR 32-PAGE BOOK
"HOW TO BUILD IT"

R-S MERCHANDISING COMMITTEE
1701 Roscoe Street Chicago, Ill., U. S. A.

Practical 56 and 112 MC Transceiver

(Continued from page 18)

much looser coupling must be used for receiving. An adjustment for a happy medium should be made in order to do away with dead spots on receive and still provide enough coupling to insure output from the oscillator into the antenna.

The coils are wound with No. 12 bare copper wire and No. 16 enameled. For 56 MC. the coil has 9 turns, spaced one diameter of the wire, on 1/2-inch tubing. The coil can be burnished or polished and then dipped in clear lacquer, or enameled wire can be used. The coil for 112 MC. is 3/8-inch diameter, of No. 16 wire, consisting of 6 turns close spaced. Much difficulty has been experienced by those who have made 112 MC. coils, shorting bars, smaller coils, etc., believing the finished coil would cover the 112 MC band. After much winding and pruning of coils, it was found that a 6-turn coil was correct for 112 MC. Lecher wires were used to check the frequency. This may solve the problem for those who have difficulty in winding 112 MC. coils. Loose coupling of the antenna midget condenser is necessary for smooth operation and elimination of dead spots on 112 MC. The usual 56 MC. antenna, as used on automobiles, will be satisfactory for 112 MC. It has been used at 6ZF without change. The length of leads and type of tuning condenser will determine the number of coil turns.

The modulator and speech stages are of the conventional type. A 42 is used as a modulator and a 76 as speech. The center-tapped choke can be an old BCL C.T. choke. It was found that interchanging the connections of the outside taps, or rather by reversing them when the proper match was found, modulation more than doubled. Most any good center-tapped choke with a large core and proper air gap will work. The cathode bias resistor is a 600-ohm 2-watt type, bypassed with a 10 mfd. electrolytic. A 500,000-ohm 1-watt resistor is shunted from the grid to ground and coupling of grid to plate of the 76 speech is made through a capacity of .01. An ordinary audio transformer was first used, but the impedance match was not correct. Coupling through a .01 condenser and 500,000-ohm resistor solved the problem. The primary of the audio transformer was left in the circuit, the secondary was disconnected.

In the 76 stage, a double primary winding of the input transformer is used. One section is used as the mike winding, the other winding is used for the input of audio from the detector. This is a Franklin transformer, double primary winding type. The mike winding is filtered with a 50 mfd. electrolytic condenser and a 100-ohm resistor, 10-watt size, is inserted in the mike supply. This eliminates any noise in the mike circuit if vibrator power supply is used. The 50,000-ohm variable resistor (regeneration control) in the audio input must be wire-wound in order to carry the load because it acts as a variable voltage dropping resistor. Carbon types should be avoided because they heat up and soon become noisy. The 250,000-ohm variable potentiometer is connected across the secondary of the input transformer; it serves as a volume control. It is connected to the receiving side of the anti-capacity switch R1.

In the oscillator section, the switch SW is not used on the receive side. This contact is used on the volume control on the send side so as to disconnect the volume control from the circuit, allowing proper output of the mike to drive the grid of the 76. A 250,000-ohm fixed resistor, 1-watt type, is

Servicemen!

Let Me Help
You Build a
REAL

**SERVICE
BUSINESS**



Naturally, I don't claim that every serviceman who has taken Sprayberry training is making "big money." But taken by and large, you'll find Sprayberry graduates forging ahead far more rapidly than competitors who drift along, relying solely on their own resources and ideas.

In almost every case, a modest investment in Sprayberry training has netted handsome dividends. Dozens of enthusiastic letters prove this.

BUT GET ALL THE FACTS!

Let me tell you about this modern course designed exclusively for forward-looking servicemen. This information will cost you nothing and, as it has already done for so many others, may point the way to a better, brighter future in the work to which you are devoting your life.

Send the coupon NOW!

F. L. SPRAYBERRY 2548 University Place, N. W.
Washington, D. C.

Without cost or obligation, please send your book "PUTTING PROFITS AND EFFICIENCY INTO SERVICING."

Name

Street

Address R 11-35

**SPRAYBERRY'S PRACTICAL
MECHANICS OF RADIO SERVICE**



Radio
Amateur
Call
Book

The only radio callbook published that lists all radio amateur stations throughout the entire World.

Also a complete list of high frequency commercial stations, International abbreviations and amateur prefixes, "Q, R, & T," systems for reporting signals, new US inspection districts and high frequency time, press and weather schedules.

Each copy contains a double post card addressed to the CALLBOOK for use in reporting your new QRA. We are extremely anxious to publish a callbook that will be 100% correct and want you to help us by checking your QRA at once in the latest edition and advise us of any errors.

PUBLISHED QUARTERLY MARCH, JUNE,
SEPTEMBER AND DECEMBER

Single Copies \$1.25

Annual Subscription USA, \$4.00

Order your copy today from your local radio jobber or direct from:

Radio Amateur Call Book, Inc.
600 South Dearborn St. Chicago, Ill.

shunted from grid to ground in order to operate the mike within proper limits and to eliminate feedback. This novel arrangement does away with the necessity of juggling the volume control from receive to send. When set in position to receive, therefore being disconnected from the circuit when on Transmit, volume remains the same when switched back to receive. The majority of transceivers do not use this method and it is therefore necessary to change the setting of it each time on Transmit or Receive. The cathode resistor is of 200-ohm 2-watt type. It is by-passed with a 10-mfd. electrolytic.

Speaker or phones can be used. A filament control jack is used in order to eliminate a switch or an extra control. Speaker connection is made off the center-tap of the choke through a .5 mfd. condenser to one side of the mike portion of the switch SW.

The remainder of the circuit is self-explanatory. An 8 mfd. electrolytic is quite essential across the input of the "B" voltage to the set, right at the plug-in socket or on the cable to the set. This acts as a by-pass of any vibrator noise, and also eliminates feedback in the power supply. A 6-volt storage battery is used for filament supply in order to eliminate hum on the carrier, although a filament transformer could be used; however, the mike battery connections must then be disconnected and an external mike battery must be used. This transceiver modulates up about 50 per cent.

W6SX at Mt. Hamilton has reported it R7 to R9 on various occasions during a nightly schedule which is held from a down-town San Francisco office. It has never yet failed to put a signal through on schedules with 6SX, 6HB and 6APP. 6SX is approximately 52 miles south of San Francisco, 6HB is in Belmont, approximately 20 miles southwest, and 6APP is in Berkeley, thirteen miles east. For such a location, in the heart of the business district of San Francisco, among tall buildings of steel structure, the results thus far secured with this flea-powered rig are remarkable. Nightly schedules are held with 6APP on 112 MC., with R8 to R9 signals on both ends. 6SX and 6HB will be on 112 by the time this is in print. Perhaps a brief report can be given next month on the results between those points.

The cost of this equipment is approximately \$25; the vibrator power supply is the most expensive, costing \$15. The power pack is an old receiver power supply delivering 300 volts. The vibrator delivers 300 volts at 100 milliamperes from a 6-volt storage battery. The battery should be of the heavy duty type, preferably 120 ampere hours. The filaments of this transceiver are operated from the car battery in order to eliminate possibility of noise from the vibrator.

The feed line from the set to the antenna (mounted on the bumper of the car) is a concentric transmission line. Western Electric No. 700 cable is used. Its loss at ultra-high frequencies is not noticeable. It works about 95 per cent better than the ordinary single-wire type. When the concentric line is used, it is necessary to insulate the bottom of the antenna from the bumper, then tap on at that end with the concentric line. The match is as close to 37 ohms for a 1/4-wave antenna as it is possible to obtain. A 1/2-wave antenna is preferable, but is quite difficult to use on a car in motion, due to the height and bracing.

Quiet Amplifier Tubes

(Continued from page 29)

The performance, as regards freedom from noise, of a vacuum tube used in an amplifier may be indicated by a comparison between the noise and a signal applied to its grid.

(Continued on page 32)

FOR BETTER RADIO

Use

Hammarlund XP-53 FORMS

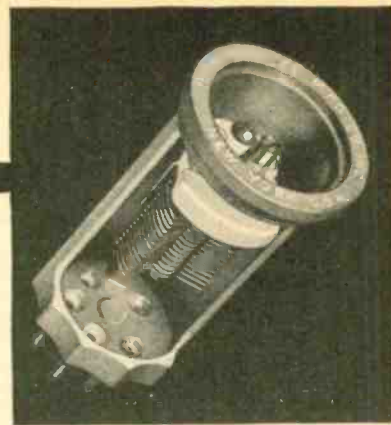

- | | |
|---|---|
| <p>1 NEW XP-53 DIELECTRIC—
NATURAL COLOR—
LOW LOSS</p> <p>2 GROOVE RIBS—
AIR SPACED WINDINGS—
CORRECT FORM FACTOR</p> <p>3 GREATER SIGNAL
STRENGTH—MORE
SELECTIVITY</p> | <p>4 FLANGE GRIPS—METER
INDEXES—EASY DRILLING</p> <p>5 4, 5 AND 6 PRONGS</p> <p>6 LOW COST!</p> |
|---|---|

For CHOKE EFFICIENCY Rely on HAMMARLUND

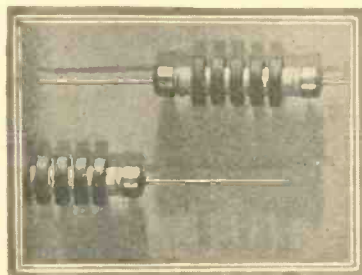

CH-X R.F. CHOKE

THE Hammarlund "CH-X" R.F. Choke is the smallest and lightest made. Its features are exclusive. Only 1/2" x 1 1/2", it is small enough for restricted space and so light that the tinned copper leads are ample support. Leads extend straight from the end caps. This makes for neater wiring.

Tinned copper end caps are small, thin and so spaced that distributed capacity to adjacent coils is at a minimum. Five moisture-proof, lattice-wound pies of high impedance. Inductance 2.1 mh. Carries 125 ma. Isolantite core. Priced low it can be used generously wherever R.F. filtering is desirable—such as detector plate circuit, all B+ leads, grid leads, etc. Only 75c each.



Write Dept. PR-11 for Catalog

Hammarlund Manufacturing Co.
424-438 W. 33rd St., New York

CALL TRIMM

when you need help with your Ear-
phone problems. A phone for every
conceivable use. Impedance values
from 1 to 100,000 ohms.

Your Jobber Can Supply You

TRIMM RADIO MFG. CO.
1528 Armitage, Chicago, Ill.



SANGAMO

Accurate

Condensers

A quality product for the amateur who
wants the best results. Available in
1000, 2500, and 5000 volt construction.

Write for catalog sheet

SANGAMO ELECTRIC CO.
SPRINGFIELD, ILLINOIS

RCA AR-60 Receiver

(Continued from page 23)

cabinet, handles are provided at each side for withdrawing the chassis from the cabinet.

Chassis. The chassis is attached directly to the panel and forms part of the RF shielding. It is flanged down on all four sides, with parts mounted both above and below it. Partitions on the underside form five compartments in which are located antenna coupling coils; RF coils; band change switches; tube sockets for RF first detector and oscillator tubes; and filters in the power supply leads. In one partition, separating two compartments at the front of the chassis, is an electrostatic shield through which coupling from the antenna coils to the first tuned circuit takes place. The bottom of the chassis is provided with a removable plated brass cover.

Tuning Capacitor. The tuning capacitor

second RF stage. In the third compartment are located the first detector switch sections and in the rear compartment the oscillator circuit switches. These sections are all individually supported to provide for self-alignment and are driven by a square stainless steel shaft which may be withdrawn without disturbing sections or wiring, so that any individual section may be removed. A detent and stops on the shaft locate the six operating positions to correspond with the frequency range positions on the panel.

Each section of the switch has its own bearing for the rotor. Both the stator plate and the rotating contact support are of Isolantite. Particular care has been taken in the design of the switch to obtain low contact resistance over long periods of time and to make the switches self-cleaning. Solid silver contact buttons are riveted to the rotating springs which made contact to heavy silver-surfaced studs mounted on the Isolantite stator plates. No pigtails are used,

Weight. The weight of the receiver complete for table mounting is approximately 80 pounds.

The weight of the receiver complete for rack mounting is approximately 72 pounds.

Overall Dimensions. The overall dimensions of the three types are as follows:

	AR-60-R	AR-60-T	AR-60-S
Height, inches	10 $\frac{1}{2}$	11 $\frac{1}{8}$	12 $\frac{1}{2}$
Depth, inches	16 $\frac{1}{4}$	16 $\frac{3}{8}$	17 $\frac{1}{8}$
Width, inches	19	19 $\frac{1}{2}$	22 $\frac{1}{4}$

Performance

Table 1 shows data taken on a sample receiver. The following statements of performance are the limits set for production receivers. The variations noted are due to practical manufacturing tolerances and normal variations in tube characteristics.

Frequency Range and Overlap. The frequency range is from 1500 to 25,000 KC, and is covered in six bands. Sufficient overlap is provided to assure freedom at all times from hiatus in the entire frequency range of the receiver.

The nominal frequency range of each band is given in the following table:

Band No.	Frequency Range (Megacycles)
1	1.50- 2.29
2	2.29- 3.63
3	3.62- 5.65*
4	5.65- 9.25
5	9.25-15.2
6	15.2-25.0

* The 3.5 to 4.0 megacycle amateur band is completely covered on this band setting due to overlap of tuning ranges for each band.

Sensitivity. An input of 2 microvolts or less, 30% modulated at 1000 cycles, applied to the receiver input through a 300 ohm artificial antenna is required to produce 6m.w. output.

Noise Equivalent (Microvolts CW). In an effort to obtain quantitative information on the noise rating of different receivers, the term "Noise Equivalent" has been coined. Noise equivalent is the input in microvolts, through the normal input circuit, which would be required to produce an output equal to the receiver noise output.

The value of the noise equivalent may be obtained by setting the receiver "Sensitivity" control to produce a readable deflection of an output meter due to receiver noise. For example, suppose the reading is 0.5 volt. A signal is then applied from a signal generator and the input to the receiver adjusted to produce any arbitrary output. Suppose the output of the receiver measures 3.0 volts with a signal input of 1.2 microvolts. Assuming that the output of the receiver varies in a straight line relationship to the input, which is correct up to the point where the receiver circuits overload, if 1.2 microvolts input gives 3.0 volts output then the output of 0.5 volt noise is equivalent to one-sixth as much input or 0.20 microvolts. This is then the noise equivalent.

It is further assumed that the reading of 3.0 volts is due entirely to the 1.2 microvolts signal and the noise voltage in the output is neglected. This assumption is permissible because the output signal and noise voltages add algebraically and are equal to the square root of the sum of the squares of the noise and signal voltages. An error of only about 1.0% is therefore introduced.

The noise equivalent should be checked under normal conditions of antenna loading, so in the measurements made on this receiver, a 300 ohm resistor was used in series with the signal generator output to simulate a transmission line or an average antenna.

Under this condition the AR-60 receiver will have a noise equivalent of 0.3 microvolts or less at the low frequency end of each band and 0.30 or less at the high frequency end of each band.

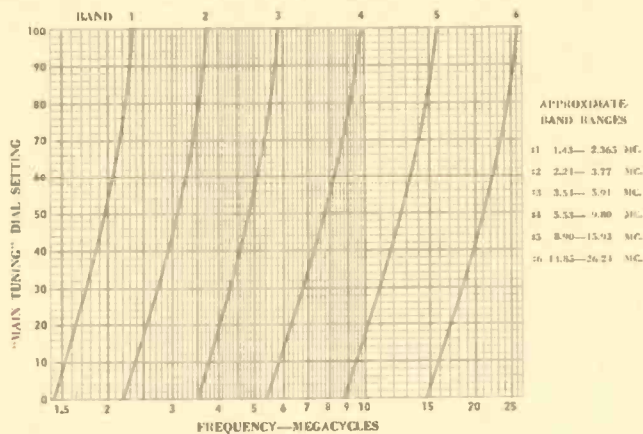

FIG. 8—Typical frequency calibration curves. Type AR-60 receivers. ("Band Spread" on 50)

is a four-gang unit with two shafts and controls, built on a cast-bronze frame and mounted on three points with the shafts running from front to rear in the center of the chassis. The shafts are mounted one above the other, the lower one carrying the four main sections, and the upper one carrying four small "band-spread" sections, each in parallel with the corresponding main section for fine tuning. The stators are mounted on Isolantite insulators, and grid coupling capacitors are attached to the capacitor frame on Isolantite insulation supports. Each shaft is driven by a cord drive with approximately

connections being made entirely by the double-armed contacts from one set of studs to another. Thus, no connection is made through bearing contacts and the shaft is insulated from RF circuits.

IF Transformers. The IF transformers are mounted in shield cans on the top of the chassis. They are composed of multi-section universal wound coils of Litz wire on Isolantite forms. Air dielectric padding capacitors are used. These are mounted on treated Isolantite bases and are adjustable from outside the shield cans.

Crystal Filter. The crystal filter unit is completely Isolantite insulated and is mounted at the rear of the chassis. A shaft from the crystal selectivity control capacitor extends to the panel and at the minimum setting of this control operates a switch which short circuits the crystal.

Materials and Finishes. Materials are selected for resistance against effects of moist, salt atmosphere. The use of ferrous materials except where necessary for magnetic purposes is kept to a minimum. All insulation material in RF and IF circuits is Isolantite. Other insulation material, such as used for resistor and terminal boards, is the best grade of cloth-base bakelite. All fixed capacitors, transformers and reactors are sealed against moisture. Audio transformers are specially impregnated and sealed to withstand actual submersion in salt water. The steel cases for transformers, filter capacitors and the reactor are given a double cadmium plate to insure complete protection. All brass and bronze parts are protected by nickel finish. Aluminum parts are protected by clear lacquer applied after a light sandblasting to secure adhesion.

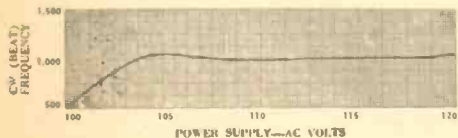

FIG. 9

Curve showing variation in CW (Beat) frequency with short period variations in line voltage (taken at 10.5 megacycles)

9 to 1 reduction from the control shafts, which are carried in bearings on the capacitor frame. Each shaft extends through the panel carrying a pointer reading on a stationary dial on the front of the panel.

Band Change Switch. The band change switch is mounted underneath the chassis with its shaft parallel to and directly beneath the capacitor shaft. It consists of eight positions. The sections in the front shielded compartment switch the first tuned circuits of the first RF tube. In the second compartment from the front, another section switches the three higher frequency circuits for the

TABLE I

Band No.	⁻¹ Noise Equiv. (CW) (Microvolts)	Image Ratio	⁻² Modulated Signal/Noise Ratio (Microvolts)	Band Spread Range (KC)	⁻³ Frequency (KC)	% Overlap	⁻⁴ Stability (Parts per million per %)
1-LF	.26	30,000	2.0	28	1,430	4.7	0.7
1-HF	.22	14,600	1.5	150	2,360	4.8	2.0
2-LF	.21	10,800	1.7	45	2,250		0.9
2-HF	.17	3,800	1.5	200	3,720	6.1	2.7
3-LF	.20	3,000	1.6	80	3,500		1.4
3-HF	.15	1,050	1.3	340	5,820	5.3	3.7
4-LF	.18	172,000	1.5	110	5,520		1.3
4-HF	.17	22,000	1.4	550	9,725	8.3	1.0
5-LF	.22	25,400	1.7	175	8,950		1.0
5-HF	.20	3,000	1.5	975	15,750	5.6	3.3
6-LF	.33	5,700	2.1	350	14,900		2.2
6-HF	.23	930	1.5	1,500	26,050	4.2	6.4

-1—See Section VI.
-2—See Section VI.

-3—Band Spread set on 50.
-4—Line voltage changed from 100 to 120 volts. See curve, Figure 4.

Modulated Signal to Noise Ratio. With the receiver sensitivity adjusted for an output of 1.5 MW noise with an unmodulated signal output, approximately 2.7 microvolts 30% modulated at 1000 cycles at the low frequency end of each band and 2.2 microvolts at the high frequency end of each band are required to produce an output of 6.0 MW signal plus noise. With a straight line detector, such as employed in this receiver, this measurement may be converted to noise equivalent by using the above method and multiplying by 0.3 (the percentage of modulation). This figure will check the CW equivalent noise within the error of measurement. Because of the difficulty of making this measurement, it is suggested that the measurements of noise equivalent made on VW be used as a standard of comparison.

Selectivity. The selectivity band width (crystal out) is less than 35 KC wide at 1000 times normal input and more than 5KC at 2 times normal input. The curves, Figures 12 and 13, were taken on a sample receiver.

Power Output. The maximum power output is approximately 500 milliwatts.

Image Response. The image ratios for the various bands of the receiver are approximately as follows.

Band No.	Ratio
1	Above 5,000
2	" 2,000
3	" 500
4	" 15,000
5	" 1,000
6	" 500

A substantial increase in image ratio is readily obtainable if the antenna coupling is reduced by means of the control on the front panel. However, reduction in coupling will be accompanied by a decrease in signal to noise ratio except under conditions where the local noise level or static exceeds the inherent receiver noise level. (See curve, Figure 7.)

AVC Characteristics. The curve, Figure 4, shows the characteristics of the automatic volume control as taken on a sample receiver.

EVERY AMATEUR NEEDS:— THE "BLUE BOOK OF AMATEUR RADIO" AND THESE "RED HOT" SPECIALS



\$1.45
until
Dec.
15 '35

Genuine Oil Impregnated Transmitting Condenser. Highest Quality. 2 Mfd.—1000 volt shown above. 2 Mfd.—2000 volt, \$2.45.

RCA
#852
only \$16.40

RCA #866
only \$2.25

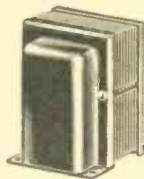

Thordarson Plate and Filament Transformer.
600-0-600 at 200 MA, 7 1/2 V. at 2 1/2 A., 5 1/2 V. at 3 A., 2 1/2 V. at 10 A.
Special price \$2.45

Heavy Duty Chokes
5 H.—200 MA special 95c
30 H.—200 MA, special — \$1.25
30 H.—300 MA, special — \$1.95

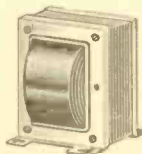

MID-WEST RADIO MART

520 SOUTH STATE STREET

CHICAGO, ILL.

Please send items checked:

- FREE "Blue Book of Amateur Radio"
- 2Mfd—1000 V. Cond.
- 2Mfd—2000 V. Cond.
- RCA 852 Tube
- RCA 866 Tube
- Thordarson Power Trans.
- 5 H.—200 MA Choke
- 30 H.—200 MA Choke
- 30 H.—300 MA Choke

Enclosed please find \$..... for checked merchandise.

Name.....

Address.....



20 TRANSMITTER CIRCUITS

THIS VALUABLE REFERENCE BOOK



FREE!

COMplete design for 12 tested transmitter R-F section circuits and 8 modulator and speech amplifier circuits. Outputs ranging from the smallest to a big broadcaster. Not only the circuit designs, but complete parts specifications. Listing transformers, inductances and all component parts. A complete handbook on transmitter design! This valuable reference book sent you free. Just tear out this advertisement and send with 12c in stamps to cover mailing expenses in order to get your free copy. There is no further obligation. Hurry! The supply is limited.



STANDARD TRANSFORMER CORPORATION

856 Blackhawk Street, Dept. B
Chicago, Illinois

Please send me the Standard Manual of Transmitter Circuits. I am enclosing 12c in stamps.

Name.....
Address.....
City..... State.....



Sargent Model 20

Short Wave Fans! Amateurs! Here It Is!

*Everything You Want
in an All-Wave
Communication Type
Super*

- One Stage Pre-Selection
- A.V.C. and Manual Volume Control
- Continuous Band Spread; Calibrated for Amateur Bands
- Coil Switching—No Plug-in Coils
- Built-in, Hum-free Power Supply
- Headphone Jack
- Excellent Broadcast Band Reception
- Ideal for Shipboard Work
- Razor-edge Selectivity
- Fractional Microvolt Sensitivity
- Outperforms Receivers selling for 3 times its price.

Everything you can possibly ask for in a communication type super-het, yet priced so you can afford to buy it. Model 20 is a well built receiver, carefully designed to amplify the weakest signals with an absolute minimum of interference and noise. Its "effective sensitivity" is extremely high, and it receives weak signals lost in the noise level on most sets.

Model 20 prices given below include an 8" Jensen speaker unit and a complete set of tubes. For speaker cabinet, finished to match receiver add \$3.25 net to these prices.

This will be the outstanding receiver of the 1936 season. **ORDER YOURS TODAY.**

AMATEUR NET PRICES

Model 20-SA, 15-550 Meters, complete.....\$59.50
Model 20-MA, 15-1500 Meters, complete.....\$67.50

IMMEDIATE DELIVERY

E. M. SARGENT CO.

212 Ninth St., Dept. R Oakland, Calif.

75 Watt Modulator (Continued from page 7)

order to prevent a distorting effect at high audio levels which, in turn, might prevent 100 per cent modulation characteristics in a Class C modulated RF stage.

Additional filtering is accomplished for the 2A3 stage by means of a semi-variable 50 watt 2000 ohm resistor and another 600 volt 8 mfd. condenser. The voltage at this point should run between 325 and 350 volts because self-bias is used on the 2A3s. Additional filtering in the form of a 20,000 ohm 5 watt resistor and an 8 mfd. condenser is used on the two 57 stages. This in effect gives three sections of filter for the first two stages of hum-free audio amplification. Triode 57 stages give more audio gain than 56 stages.

The amplifier baseboard is 24-in. x 11-in. x 1-in. with a cleat at each end so that resistors, wiring and terminal strips can be mounted under the base. The power supply baseboard is 20-in. x 8-in. x 1-in. Another power supply using a single 83 tube, heavy duty transformer and choke was also used successfully for tests at a plate voltage of 400. A plate voltage of 500 gives about 50 per cent or 60 per cent more audio output.

When speech is used, the plate current to the 46 tubes is only about half as high on speech peaks, for a given peak power output, as for a sine wave audio oscillator input. The peak power output is the same in either case, but since the average plate current is lower for speech, the plate heating is less. This allows more plate voltage to be used, and 500 volts is not too high. This in turn prevents overloading on the instantaneous voice peaks, with the result that the 46 tubes remain cool under voice operation even when modulating a Class C RF stage up to 100 per cent at a DC input of over 150 watts. For example, with two 46 tubes in the unit shown, the plates were red before an output of 30 or 35 watts was reached when a 400 cycle sine wave audio tone was impressed. Nearly 40 watts of audio was secured for speech.

With four 46 tubes, a pair of 40 watt Mazda lamps were connected across low impedance taps on the output transformer. At 500 volts plate supply, a steady sine wave tone input lit the Mazda lamps to full brilliancy, indicating at least 80 watts of audio output. As near as could be judged, 65 watts was obtained with a 400 volt supply. No attempt was made to check harmonic distortion which may have been high at this large output. The tubes showed no color, except in a dark room, even with sine wave input, as long as four 46s were used.

The total plate current drain is about 130 to 140 MA at 500 volts with no speech input, and on speech peaks the meter should not read more than 300 MA, which means that the 46 tubes never operate at more than about 160 MA on voice input. On steady sine wave tone input the plate current may increase to a total value of 350 to 400 MA for the same peak power output.

CROWE

RADIO COMPONENTS

DIALS, KNOBS and SWITCH PLATES for TRANSMITTERS, SOUND EQUIPMENT, OSCILLATORS, Etc.
CARRIED IN STOCK BY LEADING JOBBERS AND DEALERS.



No. 260

Chrome and black Gain plates in several styles and readings.

Die-cut instrument dials. Professional appearance and extreme accuracy.

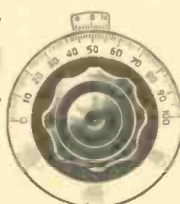

No. 292



No. 285



No. 286



No. 284



No. 283

Black Bakelite knobs in matching sets.
Bar Knobs - Switch Knobs - Skirt Knobs



No. 280



No. 275



No. 278



No. 273

Aluminum and black Switch Plates, Gain Plates, Volume and Selector Plates.

Send for Bulletin No. 75 showing other Amateur Items



No. 30

Established 1899

Representatives in Principal Over-Seas Markets

CROWE NAME PLATE AND MANUFACTURING CO.

1755 GRACE STREET

Cable Address: Crowname, Chicago

CHICAGO, ILLINOIS

LITTELFUSES

Radio men can use Littelfuse Products profitably in their work. New test instrument—pocket size—TATTELITE—cost only \$1.00. Also Littelfuses for instruments: Hi-Volt Fuses for transmitters, etc. Neon Voltage Fuses and Indicators. Aircraft, auto, radio Littelfuses—mountings. Write for catalog.

LITTELFUSE LABORATORIES

4236 Lincoln Avenue Chicago, Ill.

ENGRAVING

Instrument Panels Exclusively Since 1925

Bakelite Nameplates. List on request.

A. L. WOODY

189 W. Madison St.

Chicago, Ill.

Hi-Power for Sound Equipment



The Carter Genemotor supplies the most Reliable and Economical "B" power for Class A or B Amplifiers from a 6 or 12 volt battery. Output up to 500 volts. Sturdy — Compact — Quiet in operation — Requires no oiling — Guaranteed. Write for Bulletin showing complete line of Genemotors.

tors for every purpose or specify your requirements.

CARTER MOTOR CO.

365 W. Superior St.

Chicago

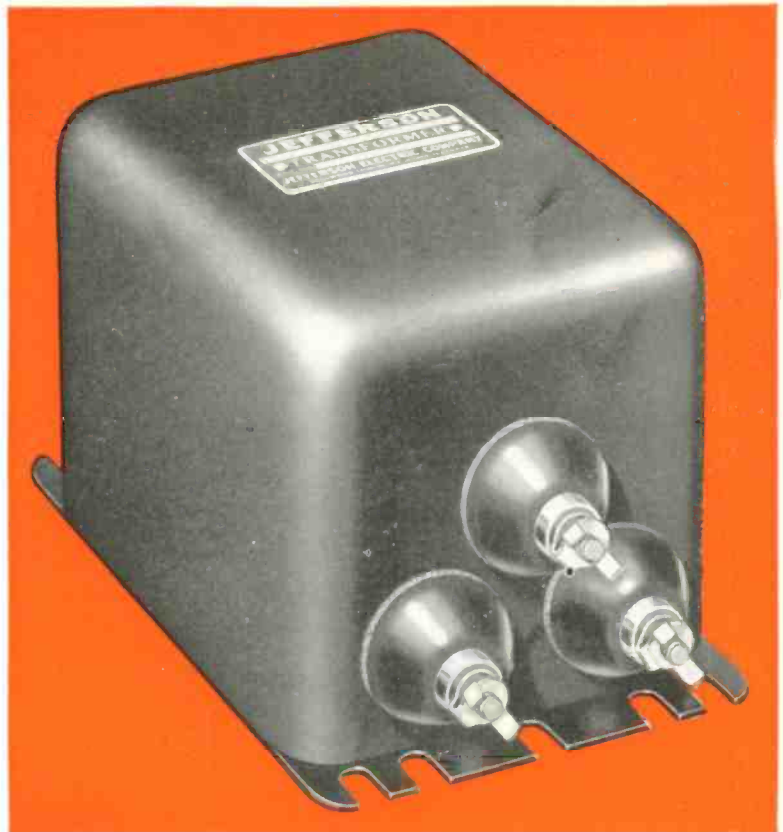

JEFFERSON Presents

New Ruggedness in Filament Transformers

THE new Jefferson Filament Transformers are designed with such margins of safety and quality that they more than meet the requirements of the radio amateur and experimenter.

In addition to liberal design, which makes for good regulation, judicious use of highest grade mica and porcelain insulation insures long life and perfect performance under every condition of service.

Adaptability to all needs is provided by the listing of multiple secondary transformers as well as by the construction of the more popular designs in either open or enclosed style mountings.

Attractive appearance has been stressed in design in keeping with typical quality construction throughout.

Jefferson Features include:

Full secondary voltages under load

Rigid test limits

Adequate Insulation

Conservative rating and construction which includes modern coil impregnation, varnish treatment and bake, high grade silicon steel, convenient terminals.

Write your wholesaler for the Jefferson catalog today. It includes a complete line of parts for amateur work.

JEFFERSON Filament Transformers

Catalog No.	Capacity V. A.	SECONDARY			Tubes	Size	Wt. Lbs.	Price
		Volts	Amps.	Insulation				
464-211	13	2.5 C.T.	5.25	1500	27, 2A3, 82, etc.	2 x 3 1/4 x 1 1/4	1	\$ 1.40
464-221	25	6.3 & 5 C.T.	4.	1500	80, 71, 5Z3, etc.	2 1/2 x 4 x 2 1/2	2	2.00
464-201	30	2.5 C.T.	12.	7500	82, 66, 27, etc.	2 1/2 x 4 x 2 1/2	2	2.00
464-241	70	10. C.T.	7.	5000	03A, 11, etc.	4 x 3 1/4 x 2 1/2	5	4.00
464-281	30	2.5 C.T.	12.	7500	66's, etc.	4 1/2 x 3 1/4 x 4	5	6.00
464-271	49	7.5 C.T.	6.5	2000	800, RK18, etc.	4 1/2 x 3 1/4 x 4	5	6.00
464-291	70	10. C.T.	7.	5000	03A, 11, etc.	4 1/2 x 3 1/4 x 4 1/2	6	6.00
464-261*	100	5. C.T.	20.	8000	872, 72A, etc.	4 5/8 x 8 1/2 x 4 1/2	12	16.00

COMBINATION TYPES								
464-191*	64	2.5 C.T. 2.5 C.T. 5.0 C.T. 2.5 C.T.	14. 1.75 3. 3.5	1500 V.	For 59 Class "B" Amplifier	4 1/2 x 3 1/4 x 3 1/4	5	4.00
464-231	38	7.5 C.T. 7.5 C.T.	2.5 2.5					
464-301	50	2.5 C.T. 2.5 C.T.	5. 5.	5000 V.	For '66 Bridge Type Rectifier	4 x 3 3/4 x 5 1/2	6	9.50
464-251*	74	7.5 C.T. 2.5 C.T.	10. 6.5 10.					

*—Has primary tap for 110 Volts

JEFFERSON ELECTRIC COMPANY, Bellwood (Suburb of Chicago), Illinois
Canadian Factory: 535 College Street, Toronto



Radio Dealers and Jobbers who desire to advertise in these columns are invited to write for rates.

RADIO BUYERS' GUIDE

A Monthly Listing of Reliable Radio Dealers and Jobbers who solicit the patronage of our readers. Buy from your nearest Dealer or Distributor. He is dependable and reliable.

CHICAGO, ILLINOIS

Chicago Radio Apparatus Company, Inc.

415 South Dearborn Street
Harrison 2276

Dependable Radio Equipment
Established 1921

Bulletins on request.
Everything for the amateur.
Get our very low prices.

CHICAGO, ILLINOIS

MID-WEST RADIO MART

520 South State Street
CHICAGO

Write for Special Catalog—Free

SCHENECTADY, NEW YORK

ATLANTIC RADIO SUPPLY CO.

712 Broadway

Complete Equipment Stocked for
Service men—Amateurs—Experimenters

Let us quote you

OAKLAND, CALIFORNIA

RADIO SUPPLY CO.

2085 BROADWAY.

Hammarlund, Yaxley, Carter, National, Johnson, IRC, Cardwell, Miller, Morrill, Flechteim, Triplett, Haigis Transceivers
W6GFY

ST. PAUL, MINNESOTA

LEW BONN COMPANY

2484 University Avenue

Rex L. Munger, W9LIP, Sales Engineer

Radio Wholesaler

Complete Stock

NEW YORK, N. Y.

227 FULTON ST.



Complete Stock of Amateur Radio Supplies
at Wholesale Discounts

LOS ANGELES, CALIFORNIA

RADIO SUPPLY CO.

912 SO. BROADWAY

The Amateurs'
HEADQUARTERS of the WEST

All Nationally Advertised Parts for
Receiving and Transmitting Carried
in Stock at All Times

9 Licensed Amateurs on Our Staff



NEW PRODUCTS



Thordarson Condenser Capacity- Leakage Tester Foundation Unit

Two valuable service instruments combined in one "build-it-yourself" design is the feature of the Thordarson Condenser Capacity-Leakage Tester Foundation Unit.

Recognizing the tendency of radio servicemen to build their own equipment, the Thordarson Electric Manufacturing Company, 500 W. Huron Street, Chicago, Illinois, have produced a foundation unit consisting of a portable walnut instrument case, an etched and drilled metal panel with a scale calibrated in microfarads, matched panel mounting screws, and complete instructions and assembly plans for a condenser capacity-leakage tester.

Most of the additional parts required to complete this unit are stock items carried by radio servicemen. The completed unit will measure capacity between 0.001 to 50 mfd. and indicate leakage on a neon glow lamp. The capacity measuring portion operates from 105 to 120 volts, 60 cycles AC employing the Wheatstone Bridge principle. The leakage-tester derives its power from the receiver in which the condenser is used and thus tests the condenser under actual operating conditions.

The foundation unit carries a list price of \$4.50 and is available through distributors at regular dealer discounts.



Filtercons to Reduce Interference



Man-made static reduction is the object of seven new types of supply line filter devices developed by Continental Carbon Inc., 13900 Lorain Ave., Cleveland, Ohio.

Filters designated for use with small motors, heater pads, vibrators, and neon transformers are of the type which prevents radiation of high frequency impulses on the supply lines. Two designs are specifically for use between a radio receiver and a power line and are of the convenient plug-in type which can be quickly connected and demonstrated. For oil burner motors and noise-producing devices with grounded frames, two filters are provided with mounting straps to be attached directly to the apparatus. Five of the seven filters employ combination network of inductances and condensers. The filters are rated to carry 5 amperes, A.C. or D.C.

CHICAGO, ILLINOIS

Chicago Radio Apparatus Company, Inc.

415 South Dearborn Street
Harrison 2276

Dependable Radio Equipment
Established 1921

Bulletins on request.
Everything for the amateur.
Get our very low prices.

SAN FRANCISCO, CALIFORNIA



1452 Market Street.

"The House of a Million Radio Parts"

Hammarlund and National sets and parts.

RCA and EIMAC Tubes

Arcturus Receiving Tubes.

Trimm Phones, all types.

Johnson Antenna Feeders, Insulators,
Transition Blocks.

FRESNO, CALIFORNIA

PORTS MANUFACTURING CO.

3265 E. Belmont Ave. Radio W6AVV
National FB7-SW3 and Parts; Hammarlund,
Cardwell, Bliley Crystals; Johnson Insulators.
Distributors RCA-DeForest Transmitting Tubes
Established 1914 Send for Wholesale Catalog

BUTLER, MISSOURI

HENRY RADIO SHOP

Complete stock of RCA, Collins, Patterson, National, Hammarlund, Silver, RME9D, Super-Skyrider, Peake, Mac-Keys, Eimac, Taylor, Thordarson, Cornell-Dubillar, Cardwell, Dwyer, Triplett, Weston, Turner, Astatic, Trimm, Johnson, Bliley, and others at lowest wholesale prices. Your used apparatus accepted in trade, too. Write for any information.

Robt. Henry, W9ARA, Owner, 211-15 N. Main St.

CHICAGO, ILLINOIS

Newark Electric Company

226 W. Madison St.

Chicago

All Kinds of Equipment for

Service Men - Amateurs - Experimenters

Write for free catalog

HEY, HAMS!!

DID YOU KNOW—

That for the past ten years Amateurs in all parts of the world have depended upon Harrison for all their Ham equipment! — Everything from a Xtal to a Xmitter!

Prompt Service — Lowest Prices — and Honest Dealing with a 100% money back guarantee — are the reasons!!

Anything you need can be quickly and economically obtained from Harrison. Send us your next order and be pleasantly surprised!

73 dc Bill Harrison, W2AVV

Send for Free Ham Bulletins!!

HARRISON

RADIO COMPANY

142 Liberty St., Dept. AN New York City

Visit our new large salesrooms

THE **NEW** in RADIO • AND **ALL** THAT IS **NEW!**

The New 1936 **CROSLEY** Line

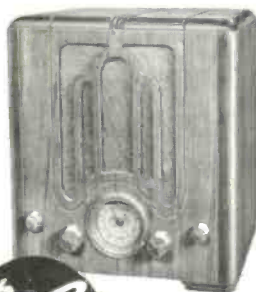

\$19.99

THE
CROSLEY FIVER
Table and Console

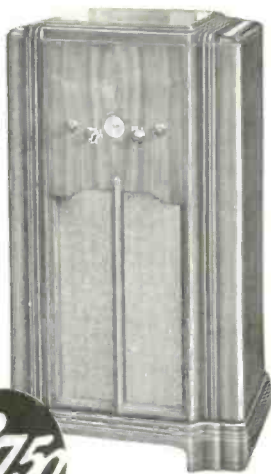

\$37.50

CHASSIS—Five-tube superheterodyne. Two bands—Standard and police, amateur, aviation broadcasts. Illuminated full-vision airplane type dial—5 to 1 ratio drive. Tone control. New 6B5 Triple-Twin output tube. Full floating moving coil electro-dynamic speaker.

CABINETS—Half an eye can see their beauty and charm—equal in every way to their superb tone. Between these and the Constitution models are a full range of receivers for every purse and type of use.

From the Fiver, giving standard, police, aviation, amateur reception for \$19.99 to the **CONSTITUTION** five-band metal tube all-wave that gets virtually all that's on the air . . . the new Crosley 1936 Line leads the field. In every price range the Crosley gives more for the money in beauty, performance, selectivity . . . in everything that makes for radio satisfaction.

FEATURES! Innovations! Master-strokes of engineering. In this new 1936 radio line Crosley has tapped all the resources of experience dating back to the pioneering stage; all the creativeness and inventiveness of today. Never has a line so stepped out to capture the imagination of a country. Never a line with so many "want-able" features. Never a line with equal value for the radio dollar.

The beauty of the line is alone an eye-stopper anywhere. But the more you explain the in-built quality, the new features, the reason for the extraordinary tone, selectivity, truthfulness of reproduction . . . the more your customers will select—from this line—the set that best fits their means and their wants.

Everywhere the groundwork of **SALES** is being laid with this line. Get in on this from the start by getting in touch with your Crosley distributor.

THE CROSLEY RADIO CORPORATION

CINCINNATI POWEL CROSLEY, Jr., President
Home of "the Nation's Station"—WLW—500,000 watts
—most powerful in the world—70 on your dial.

Prices in Florida, Rocky Mountain States
and West slightly higher.



\$49.95

THE
CROSLEY CONSTITUTION
Table and Console

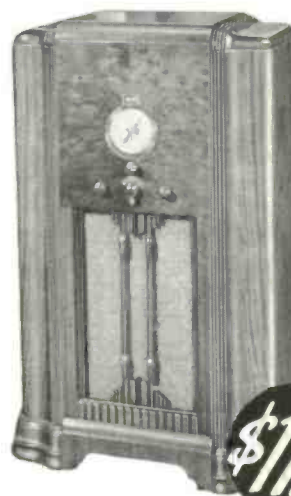

\$71.50

CHASSIS

This all-wave 10-tube superheterodyne using all-metal tubes, commands the air. Five bands, receiving American, foreign, weather, amateur, police, aviation broadcasts. Shadow tuning. Automatic volume control. Full-vision airplane type dial. Tone control. Dual ratio tuning control. Full floating moving coil electro-dynamic speaker.

AMONG THE FEATURES...

Three-gang tuning condenser with many notable improvements.

New velvet action two-speed dial—planetary bull-bearing drive.

New high-wattage, metal-to-metal tone control—far superior to conventional tone control.

New triple-tuned I. F. transformer—far better selectivity, higher fidelity.

New H-Q-I-layer bank wound Litzendraht broadcast coils—providing better signal-to-noise ratio.

All-metal tube and all-glass tube models—a set for every need.

NEW SHADOW TUNING. NEW 5-COLOR AIRPLANE DIAL

NEW COLOR-BAND DESIGNATION.

You're there WITH **CROSLEY**

Variactor Controlled Carrier Modulation

Phone Men who have switched over to Variactor Controlled Carrier Modulation agree it is the most economical and practical, least critical and simplest of any system of Controlled Carrier Modulation in use.

THE UTC SYSTEM OF VARIACTOR CONTROLLED CARRIER MODULATION:

- ★ Increases DX coverage many times over.
- ★ Allows power consumption savings of 50% or over.
- ★ Almost doubles Class C tube ratings and will double to quadruple Class B Linear Tube ratings.
- ★ Reduces interference between stations tremendously.
- ★ Increases tube life and power efficiency. Using the UTC Variactor CCM System the changeover from standard carrier to controlled carrier can be accomplished in less than an hour.

CV VARIACTORS FOR CONTROLLED CARRIER CLASS C

	List Price	Net to Home
CV-1 25 to 50 watts maximum input controlled class C	\$ 7.50	\$ 4.50
CV-2 50 to 100 watts maximum input controlled class C	10.00	6.00
CV-3 100 to 170 watts maximum input controlled class C	15.00	9.00
CV-4 170 to 300 watts maximum input controlled class C	20.00	12.00
CV-5 300 to 500 watts maximum input controlled class C	25.00	15.00
CV-6 500 to 800 watts maximum input controlled class C	33.00	19.80

AV AUTOTRANSFORMERS FOR CV VARIACTORS 115/170 VOLTS AC

	List	Net
AV-1 for use with CV-1	\$ 5.00	\$3.00
AV-2 for use with CV-2	6.00	3.60
AV-3 for use with CV-3	7.00	4.20
AV-4 for use with CV-4	9.00	5.40
AV-5 for use with CV-5	12.00	7.20
AV-6 for use with CV-6	15.00	9.00

SEE 1935 MARCH, APRIL, MAY, AUGUST and SEPTEMBER issues of RADIO for further technical details.

UTC Audio Power and Filter Components for High Powered Broadcast Transmitters

Typical Utc units used in better equipped High Fidelity Broadcast Stations

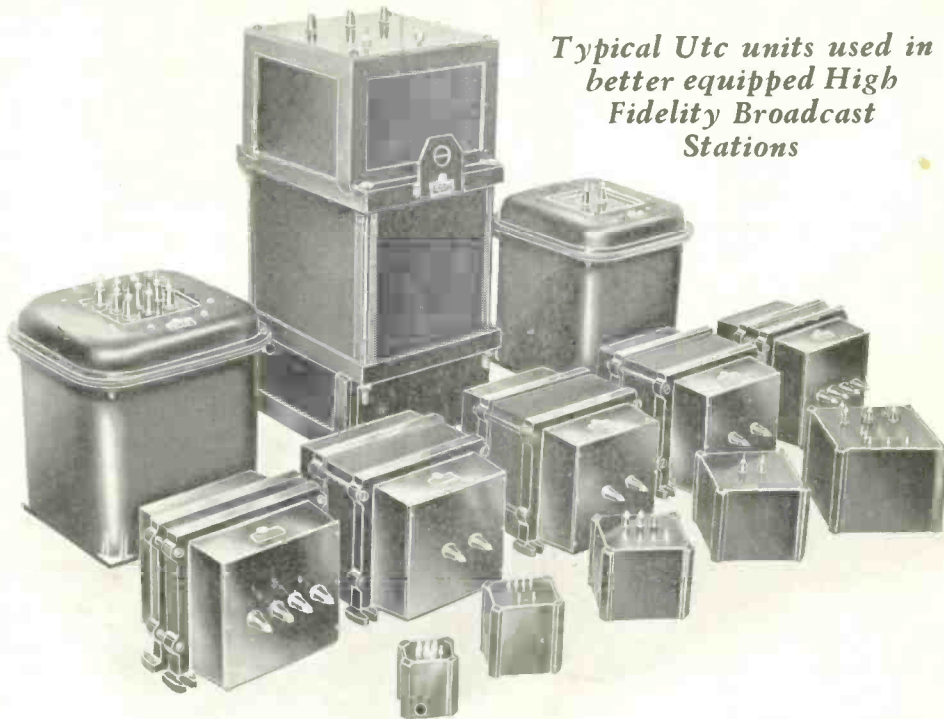

The units illustrated—top row, left to right—are: an oil-filled class B output transformer; plate transformer for output and RF stage; oil-filled modulation reactor. Second row, left to right: audio and filter reactors. Bottom row: speech and voltage amplifier audio units, etc.

UTC specializes in custom-built audio transformers in power ranges of —120 DB. to 50 KW.; power transformers to customer's specifications in dry or oil-filled types from 1 watt to 100 KVA.—up to 100,000 volts.

UTC has set a new precedent in matched audio units used by high fidelity broadcast and communication systems.

UTC LINEAR STANDARD and HI-PERM ALLOY audio transformers are calibrated and guaranteed to be ± 1 DB. from 30 cycles to 20,000 cycles. All pertinent technical data and frequency response in DB. indelibly imprinted on outer transformer shield for customers' protection.



PA 134 Shield

AND NOW ...

Hum-balanced Input Transformers at a Popular Price

The true hum-balancing audio transformer is an original and exclusive development of the UTC engineering department. The coil structure in these transformers is so balanced that practically any linear form of magnetic flux will cut opposing coil sections in opposite directions and cause neutralization of inductive pickup. The hum-balanced transformer is further shielded by a husky sheet metal case of soft magnetic iron of such proportions and dimensions as to give maximum shielding effect.

Proper use of "A" metal nickel iron alloy core material has made possible a frequency characteristic unusually fine for material of this price range.

	List	Net
PA134—500, 200, or 50 ohm line to single grid	\$6.50	\$3.90
PA135—500, 200 or 50 ohm line to push pull grids	7.50	4.50
PA136—Single plate and 500, 200 or 50 ohm line to one or two grids	7.50	4.50

UNITED TRANSFORMER CORP.

72-78 SPRING STREET

Export Division, 15 Laight St., New York, N. Y.

NEW YORK, N. Y.

Exclusive UTC distributors carrying a complete stock of UTC products.

Goldhamer's, Inc.	610 Huron Road, Cleveland, Ohio
Wholesale Radio Service Co., Inc.	100 Sixth Ave., New York, N. Y.
Wholesale Radio Service Co., Inc.	219 Central Ave., Newark, N. J.
Wholesale Radio Service Co., Inc.	430 W. Peachtree St. N. W., Atlanta, Ga.
Wholesale Radio Service Co., Inc.	911 Jackson Blvd., Chicago, Ill.
Sun Radio	227 Fulton Street, New York, N. Y.
Gross Radio, Inc.	51 Vesey Street, New York City
Leeds	45 Vesey Street, New York City
South West Radio Supply	107 South St. Paul St., Dallas, Texas
Mohawk Electric Co.	1335 State St., Schenectady, N. Y.
Walter Ashe	1100 Pine St., St. Louis, Mo.
Radio Shack	46 Brattle St., Boston, Mass.
Harvey's Radio	105 W. 43rd St., New York, N. Y.
United Radio Service	616 Main St., New Britain, Conn.
Hatry & Young	203 Ann St., Hartford, Conn.
Marine Radio Co.	124-13 101st Avenue, Richmond Hill, N. Y.

Hall's	35 So. Cameron, Harrisburgh, Penna.
Herbach & Rademan	438 Market St., Philadelphia, Penna.
Cameradio Company	603 Grant Street, Pittsburgh, Pa.
W. H. Edwards & Co.	32 Bway, Providence, R. I.
Seattle Radio Supply, Inc.	2319 Second Ave., Seattle, Wash.
Portland Radio Supply Co.	1300 W. Burnside, Portland, Ore.
Spokane Radio Co., Inc.	611 First Ave., Spokane, Wash.
San Francisco Radio Exchange	1284 Market St., San Francisco, Calif.
Straus Frank Co.	San Antonio, Galveston, Houston and Austin, Texas
SOUTHERN CALIFORNIA	
Pacific Radio Exchange Inc.	729 S. Main St., Los Angeles
Radio Supply Co.	912-14 S. Broadway, Los Angeles
Coast Electric Co.	744 G. St., San Diego
Prest & Dean Radio Co.	400 American Avenue, Long Beach
Radio Television Supply Co.	1701 S. Grand Ave., Los Angeles, Calif.
Radio Specialties Co.	1516 West 8th St., Los Angeles, Calif.